

Journal Pre-proof

2020 update on human coronaviruses: one health, one world

Xinbin Zhao, Yuecheng Ding, Jing Du, Yubo Fan

PII: S2590-0935(20)30017-5

DOI: <https://doi.org/10.1016/j.medntd.2020.100043>

Reference: MEDNTD 100043

To appear in: *Medicine in Novel Technology and Devices*

Received Date: 27 April 2020

Revised Date: 4 August 2020

Accepted Date: 19 August 2020

Please cite this article as: Zhao X, Ding Y, Du J, Fan Y, 2020 update on human coronaviruses: one health, one world, *Medicine in Novel Technology and Devices*, <https://doi.org/10.1016/j.medntd.2020.100043>.

This is a PDF file of an article that has undergone enhancements after acceptance, such as the addition of a cover page and metadata, and formatting for readability, but it is not yet the definitive version of record. This version will undergo additional copyediting, typesetting and review before it is published in its final form, but we are providing this version to give early visibility of the article. Please note that, during the production process, errors may be discovered which could affect the content, and all legal disclaimers that apply to the journal pertain.

© 2020 The Author(s). Published by Elsevier B.V.

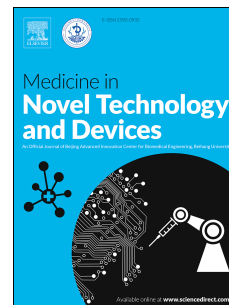

2020 update on human coronaviruses: one health, one world

Xinbin Zhao¹, Yuecheng Ding², Jing Du^{1,3,*}, and Yubo Fan^{1,3,4,*}

¹ Key Laboratory for Biomechanics and Mechanobiology of Chinese Education Ministry, School of Biological Science and Medical Engineering, Beihang University, Beijing 100191, China

² School of Public Health, Peking University, Beijing 100871, China

³ Beijing Advanced Innovation Centre for Biomedical Engineering, Beihang University, Beijing 100191, China

⁴ Key Laboratory of Human Motion Analysis and Rehabilitation Technology of the Ministry of Civil Affairs, National Research Center for Rehabilitation Technical Aids, Beijing 100176, China

* Correspondence: dujing@buaa.edu.cn (Jing Du), yubofan@buaa.edu.cn (Yubo Fan).

Abstract

Since human coronavirus (HCoV) was first described in the 1960s, seven strains of respiratory human coronaviruses have emerged and caused human infections. After the emergence of severe acute respiratory syndrome coronavirus (SARS-CoV) and Middle East respiratory syndrome coronavirus (MERS-CoV), a pneumonia outbreak of coronavirus disease 2019 (COVID-19) caused by a novel coronavirus (SARS-CoV-2) has represented a pandemic threat to global public health in the 21st century. Without effectively prophylactic and therapeutic strategies including vaccines and antiviral drugs, these three coronaviruses have caused severe respiratory syndrome and high case-fatality rates around the world. In this review, we detail the emergence event, origin and reservoirs of all HCoVs, compare the differences with regard to structure and receptor usage, and summarize therapeutic strategies for COVID-19 that cause severe pneumonia and global pandemic.

Keywords

Human coronavirus, reservoirs, gene structure, receptor usage, therapeutic strategies

Introduction

Over the past 20 years, three previously unknown coronaviruses, SARS-CoV, MERS-CoV and SARS-CoV-2, have emerged¹⁻³. The outbreak of COVID-19, caused by SARS-CoV-2, becomes a global public health emergency after the 1918 H1N1 influenza pandemic⁴. Since the outbreak of COVID-19 later in 2019 in Wuhan city of China, the coronavirus has spread to 213 countries, areas or territories with nearly 3,000,000 confirmed cases and over 200,000 deaths all over the world as of April 27, 2020. While the other HCoVs induce mild upper respiratory diseases, the three highly pathogenic viruses attack the lower respiratory system in humans^{5,6}. The current study demonstrates that the novel coronavirus emerged in 2019 is more transmissible than SARS-CoV in 2002⁷. The lack of effective therapeutic strategies for COVID-19, which causes global pandemic and has high morbidity and mortality rates, highlights the need for vaccines and antiviral drugs⁸. In this review of the seven human coronaviruses, we detail the emergence events, summarize the origin and evolution, highlight the biological features comprised of gene structures, protein organizations, receptor usage and cell entry. At last, we discuss current knowledge of prophylactic and therapeutic strategies including vaccines development and drugs discovery for these three highly pathogenic coronaviruses and expect to bring valuable countermeasures against COVID-19 and novel coronaviruses emerged in the future.

Coronaviruses (CoVs) are enveloped viruses with a single-strand, positive-sense RNA genome approximately 26–32 kb in size, which is the largest known genome among all RNA viruses. The term ‘coronavirus’ refers to the appearance of CoV virions considering the protruding spike proteins on their surface that look like a crown under electron microscopy (“*corona*” means crown). The first coronavirus is an infectious bronchitis virus and was isolated from chicken embryos in 1937⁹, along with subsequent viral isolations in rodents, domestic animals, and humans.

Coronaviruses have been identified in many mammalian animals including humans and avian species and can induce various severe diseases involving respiratory, gastrointestinal, enteric, and neurological systems.

Coronaviruses belong to the subfamily *Coronavirinae* in the family *Coronaviridae* and the order *Nidovirales*. *Coronaviridae* are further subdivided phylogenetically into four genera *Alphacoronavirus*, *Betacoronavirus*, *Gammacoronavirus* and *Deltacoronavirus*. *Alphacoronaviruses* and *Betacoronaviruses* are found in mammals, whereas *Gammacoronaviruses* and *Deltacoronaviruses* are primarily found in birds. International Committee of Taxonomy of Viruses (ICTV) in 2018 claimed that *Betacoronavirus* lineage was reclassified into five subgenera, namely *Embecovirus*, *Sarbecovirus*, *Merbecovirus*, *Nobecovirus*, and *Hibecovirus*. HCoV-229E in the subgenus *Duvinacovirus* and HCoV-NL63 in the subgenus *Setracovirus* belong to the *Alphacoronavirus* genus. HCoV-HKU1 and OC43 in the subgenus *Embecovirus*, MERS-CoV in the subgenus *Merbecovirus*, SARS-CoV and SARS-CoV-2 in the subgenus *Sarbecovirus* belong to the genus *Betacoronavirus*^{10,11} (Figure 1).

1. Emergence and Identification of HCoVs

The first human coronavirus was identified in 1965 in humans infected with the common cold¹². The aetiology of the common cold was considered to be a bacterium before Doches et al found that the viruses were likely causative agents in the 1930s (Figure 2). By 1965, a substantial proportion of colds seemed not to be caused by known myxoviruses such as influenza and parainfluenza viruses. Strain B814 was the first human coronavirus isolated from a patient with a cold but it was lost in the laboratory.

1.1 HCoV-229E and OC43.

HCoV-229E was harvested from the respiratory tract in patients with the common cold by Hamre and Procknow in 1965¹³. HCoV-OC43 was isolated from a nasopharyngeal washing patient by McIntosh and his colleagues in 1967¹⁴. HCoV-229E and OC43 respectively survived in WI-38 lung fibroblast cells and human embryonic cell culture. Having been subsequently detected worldwide, these two coronaviruses present the same clinical symptoms including headache, sneezing, runny nose, and sore throat but rarely infections of the lower respiratory tract⁵. These infections are usually self-limiting and require no specific treatment or therapy.

1.2 HCoV-NL63 and HKU1.

HCoV-NL63 was identified from the nasopharyngeal aspirate of an infant with bronchiolitis, fever, coryza, and conjunctivitis in Amsterdam, Netherlands in 2004¹⁵. The patient had mild respiratory tract infection symptoms like the common cold (fever, cough, and rhinorrhea)¹⁶. HCoV-HKU1 was first identified from the nasopharyngeal aspirate in a Hong Kong patient with bronchiolitis and pneumonia in 2005¹⁷. It's challenging to study HKU1 considering that HKU1 viruses cannot be propagated in continuous cell lines. In 2013, Dijkman et al. isolated HKU1 viruses from clinical specimens by using primary, differentiated human tracheal bronchial epithelial cells cultured at an air-liquid interface¹⁸. HCoV-NL63 and HKU1 are widespread globally and associated with upper respiratory tract infections (URTI)

including fever, running nose, and cough. Furthermore, they also cause mild to serious lower respiratory tract infections (LRTI) in infants and children with bronchiolitis and pneumonia¹⁹.

1.3 SARS.

Severe acute respiratory syndrome (SARS) first emerged in Foshan City, Guangdong, China in November 2002 (<https://www.who.int/ith/diseases/sars/en/>). In April 2003, SARS-CoV, a novel coronavirus which could cause an unusual epidemic of atypical pneumonia, was identified under global containment effort^{1,20}. Being highly transmissible among human, SARS rapidly spread to other provinces in China causing significant outbreaks and then to other countries in Southeast Asia including Singapore and Vietnam in only 9 months²¹⁻²³. SARS-CoV infected patients present early systemic symptoms with malaise, headache, myalgia, fever, dry cough, and shortness of breath, followed by respiratory distress generally and develop severe pneumonia by week 1-2 of illness, which may result in death. By July 2003, SARS-CoV had caused more than 8000 laboratory confirmed cases and 780 deaths with a 9.6% case fatality rate (CFR) in 29 countries (<https://www.cdc.gov/sars/surveillance/absence.html>). The first epidemic of SARS ended in July 2003, as announced by the World Health Organization (WHO) (www.who.int/csr/don/2003_07_05/en). Next year, five additional SARS cases from zoonotic transmission emerged without human SARS cases detected in Guangzhou City, China²⁴. However, four SARS infected cases occurred with neither mortality nor further transmission²⁵.

1.4 MERS.

A 60-year-old man presented a fatal pneumonia and acute renal failure and died in June of 2012 in Saudi Arabia. MERS-CoV, as a novel coronavirus, was identified from his sputum of lungs². MERS-CoV caused diseases, ranging from asymptomatic to atypical pneumonia along with renal failure and gastrointestinal symptoms, are often fatal²⁶. A typical infection caused by MERS-CoV first starts from fever, cough, and shortness of breath to pneumonia and dyspnea rapidly. As of January 15, 2020, 2506 totally confirmed cases of MERS, and 862 related deaths with a CFR of 34.4% were reported worldwide (<https://www.who.int/csr/don/31-january-2020-mers-united-arab-emirates/en/>). The majority of these cases were reported from Saudi Arabia with 2102 cases (CFR=37.1%) according to the WHO. Because MERS-CoV does not transmit easily between humans unless there is close contact, lots of MERS cases were independent clusters and confined to the countries in the Middle East, especially in KSA (approximately 80%). Outside of this region, 27 countries have reported cases of MERS in African, Asia and Europe and the USA in person who went to the Middle East or was in contact with those who did.

1.5 COVID-19.

On December 12, 2019, 27 cases (41 cases revised subsequently) of unknown cause of pneumonia was firstly reported by Wuhan Municipal Health Commission in Wuhan, Hubei Province, China³. Actually, the date of symptom onset of the first known case is December 1, 2019 basing on retrospective analyses of clinical data

later²⁷. A novel coronavirus was identified through unbiased sequencing of bronchoalveolar-lavage fluid from patients on December 21, 2019⁶ and the WHO was informed of the cases cluster on December 31, 2019. Twenty seven of 41 patients had a history of direct exposure to the Huanan seafood wholesale market where a number of non-aquatic animals such as poultry, birds, snakes, and other wildlife animals were on sale before the outbreak^{27,28}. Studies have demonstrated person-to-person transmission via droplets or in contact with a patient directly²⁹. Eight children were reported to be persistently positive testing on rectal swabs, suggesting the potential for fecal–oral transmission³⁰. Typical symptoms of these infections include fever, dyspnea, muscle ache, dry cough, sore throat, and diarrhea. Disease onset includes bilateral pneumonia, multiple mottling and ground-glass opacity by transverse chest x-ray and CT images³¹. On January 8, 2020, a novel coronavirus was isolated from a Wuhan pneumonia patient and two days later the complete viral genome sequence were determined along with first fatal case reported³². The virus was tentatively named by WHO as the 2019 novel coronavirus (2019-nCoV) on January 12, 2020, eventually recognized by the Coronavirus Study Group of ICTV based on phylogeny, taxonomy and established practice as SARS-CoV-2³³, which infected disease was named COVID-19 meanwhile by WHO on February 11, 2020. COVID-19 outbreak coincides with the Chinese Spring Festival, during which about 3 billion trips were made through China, with 15 million trips happening in Wuhan in 2020. As April 27, 2020, at total of 84,341 laboratory confirmed cases have been detected in China, including 4643 deaths (CRF=5.5%). Infections in medical workers of more than 3000 cases and family clusters were also reported³⁴. However, the number of COVID-19 cases was reversed, controlling the confirmed cases to 29,839 with the Wuhan travel ban and the national emergency response, 96% fewer than expected 744,000 cases in the absence of interventions by an epidemic model analysis³⁵. SARS-CoV-2 is more infectious than the other two highly pathogenic coronaviruses, and can be transmitted in asymptomatic or presymptomatic infections. To date, SARS-CoV-2 has rapidly spread to 213 countries/territories/areas worldwide. Almost 3,000,000 confirmed cases and more than 200,000 deaths have been counted in the world, which is from situation report of WHO. Given how far the virus has spread and its devastating global impacts, WHO has declared the COVID-19 outbreak a global pandemic.

2. Origins and Reservoirs of HCoV-229E, NL63, OC43 and HKU1

Bats are ancient and diverse mammals with the second largest number of species. Over 1000 species of bats belong to the *Chiroptera* order and traditionally include two suborders: the megabats and the microbats, which are mostly frugivorous and insectivorous respectively. Recently the classification is revised: *Yinpterochiroptera* and *Yangochiroptera*. Bats are recognized to be possible reservoirs to a wide variety of viruses, which could infect humans and domestic animal species³⁶. These viruses include coronaviruses, henipaviruses, filoviruses, lyssaviruses and several highly pathogenic ones, such as Hendra virus, Nipah virus and Ebola virus³⁷⁻⁴⁰. Bats have been recognized as the natural reservoirs of many human coronaviruses⁴¹ (Table 1).

2.1 HCoV-229E, NL63, OC43 and HKU1

Firstly, natural reservoirs of HCoV-229E and NL63 were recently found in African bats. HCoV-229E-like viruses, whose RNA-dependent RNA polymerases fragment had a 92% identity with HCoV-229E, were found in *Hipposideros* bats⁴² and the intermediate reservoirs of HCoV-229E are likely camelids⁴³. HCoV-NL63-like viruses have been found in *Triaenops afer* bats^{44,45}. Unlike *Alphacoronavirus* genus and other *Betacoronavirus* subgenus, HCoV-OC43 and HKU1 from the subgenus *Embecovirus* seem more likely to originate from rodents^{46,47}. Furthermore, agriculturally important animals include cattle or swine are thought to be intermediate hosts of HCoV-OC43^{48,49}.

2.2 SARS-CoV

SARS-CoV was initially identified in Himalayan palm civets (*Pagkuma larvata*), raccoon dogs (*Nyctereutes procyonoides*) and Chinese ferret badgers (*Melogale moschata*) considering that early SARS cases contacted with animals from live animal markets in Guangdong, China⁵⁰. However, large-scale epidemiological research soon revealed civets were not the natural hosts of SARS-CoV, which was not found in the wild or domestic civets without live animal market exposure^{40,51}. In 2005, novel SARS-related coronaviruses (SARSr-CoVs), known as SARS-like coronaviruses (SL-CoVs) were found in horseshoe bats (*Rhinolophus* genus) in China. Genome sequences of these bat SL-CoVs manifested nearly 90% identity to human or civet SARS-CoV^{40,52}. In addition, RsSHC014 and Rs3367, as two novel SL-CoVs found in 2013, were found in horseshoe bats⁵³. SARS-CoV is possible origin from recombination of different SL-CoVs because of frequent RNA recombination within coronaviruses. So far, most bat SL-CoVs were found in a variety of horseshoe bats species (genus *Rhinolophus* of suborder *Yinpterochiroptera*)⁵⁰. Bats are now generally thought to be natural reservoirs and civets and other small carnivore are intermediate hosts of SARS-CoV.

2.3 MERS-CoV

Most early MERS infected patients were independent clusters and only appear in the Middle East countries, especially in Saudi Arabia. Some cases were reported to contact with dromedary camels, a major livestock species in the Middle East^{26,54}. The whole genomic sequences of human MERS-CoVs and camels in the Middle East have a 99% identity⁵⁵⁻⁵⁷. Moreover, serum samples collected from camels in the Middle East, Africa and Asia were positive for antibodies against MERS-CoV^{56,58}. There's a lot of evidence that camels are the primary zoonotic hosts for MERS-CoV, however, subsequent work suggests bats are the ancestral reservoir host⁵⁹⁻⁶¹. Based on genomic sequence analysis, MERS-CoV and bat CoVs belong to the *Merbecovirus* subgenus, which have been detected from a variety of bats in suborder *Yangochiroptera* of *Betacoronavirus* genus⁶². Bat coronaviruses (BatCoVs), including HKU4 and HKU5 prior to the emergence of MERS-CoV, were discovered in various bat species that belong to the *Vespertilionidae* family⁶³. Since the emergency of MERS, MERS-related coronaviruses (MERSr-CoVs) were identified in various bat species and countries⁶⁴⁻⁶⁶. Taken together, dromedary camels may have important roles as intermediate reservoirs for person to person transmission and bats are likely the ancestral hosts for MERS-CoV.

2.4 SARS-CoV-2

COVID-19, an emerging coronavirus infection induced by SARS-CoV-2, may originate in Huanan seafood wholesale market. About a month later after COVID-19 outbreak, Chinese scientists published new coronavirus genome sequence information, revealing that the virus exhibited an 89.1% identity to SL-CoVs which originated from bats. Phylogenetic analysis suggested that the novel coronavirus clustered with members of the subgenus *Sarbecovirus* of genus *Betacoronavirus*, including the SARS-CoV and SL-CoVs from bats³². Meanwhile, another research group obtained whole genome sequences from five patients and found that the virus shares a 96.2% identity to a bat coronavirus, RaTG13, which was discovered from horseshoe bats (*Rhinolophus affinis*) in Yunnan Province⁶⁷. However, the ~4% difference means 17% divergence at the neutral sites because the genomic average dS value is 0.17, suggesting the large divergence between SARS-CoV-2 and RaTG13⁶⁸. Furthermore, the receptor binding domain (RBD) of SARS-CoV-2 is only ~85% identical and only share one of six critical residues with RBD of RaTG13⁶⁹. SARS-CoV-2 had 79.5% sequence similarity to SARS-CoV and formed a distinct lineage compared with SL-CoVs based on phylogenetic tree⁶⁷. SARS-CoV-2 contains a polybasic cleavage site insertion between the two subunits of the spike protein, which is also observed in RmYN02 sampled in another *Rhinolophus* bat from Yunnan province^{67,70}. It cannot be proved that emergence of SARS-CoV-2 comes from a recent recombination event⁷¹, but recombination may have happened before 2009, when the SARS-CoV-2 ancestors in bats first acquired genetic characteristics of SARS by incorporation of a SL-CoV RBD⁷².

Bats are thought to be likely native reservoirs for SARS-CoV-2, but bat-derived coronavirus rarely infect humans directly without an intermediate host considering the contradictions that COVID-19 emerged during the hibernation of bats. It seems to be likely that the novel virus is probably transmitted to humans by another intermediate host, as previously described coronaviruses. Pangolins are likely the intermediate host of the SARS-CoV-2 by full-length genome sequence comparison with coronaviruses from Malayan pangolins. The spike protein of the pangolin-CoV, which is responsible for receptor binding domain, is virtually identical to that of SARS-CoV-2, with one amino acid difference^{73,74}. Metagenomic sequencing identified a novel pangolin-CoV, which was isolated from SL-CoVs positive Malayan pangolins during 2017-2018, with approximately 85.5% to 92.4% similarity to SARS-CoV-2⁷⁵. Prior to the emergence of COVID-19, SL-CoVs had been detected in two dead Malayan pangolins with a frothy liquid in lung⁷⁶. The order *Pholidota* includes the eight living species of pangolins worldwide (*Manis javanica*, *Manis pentadactyla*, *Manis crassicaudata*, *Manis culionensis*, *Manis tricuspis*, *Manis tetradactyla*, *Manis gigantea* and *Manis temminckii*)⁷⁷. All the eight pangolin species are regarded as critically endangered because of the huge demand for people in food and medicines. The Huanan seafood wholesale market where wild animals including Malayan pangolins were sold, was initially thought to be the origin of COVID-19, considering that SARS-CoV-2 was identified in initial patients in contact with the market. Therefore, pangolins could be one of the potential intermediate reservoirs for

SARS-CoV-2. Further research is needed to confirm pangolins as an intermediate host and find other potential intermediate reservoirs.

3. Genome Structure and Organization

Coronaviruses particles consist of four or five structural proteins along with various minor components including nonstructural proteins (nsp). Human coronaviruses have a similar genome structure and protein organization, including an open reading frame ORF1a/b to encode 16 nonstructural proteins (nsp1 through nsp16). The large overlapping polyproteins, ORF1a and ORF1b, commonly referring to pp1a and pp1b, comprise approximately 2/3 of the genome and encode the replicase polyprotein. These polyproteins are cleaved by papain-like cysteine protease (PLpro, resides within nsp3) and 3C-like serine protease (3CLpro, also known as main protease Mpro, resides within nsp5) to produce nsps, including RNA-dependent RNA polymerases (RdRp, resides within nsp12) and helicase (Hel, resides within nsp13) shown in Figure 3. The remaining 1/3 of the genome mainly encodes four structural proteins: spike (S), envelope (E), membrane (M), and nucleocapsid (N), and some also encode a hemagglutinin esterase (HE) protein which are encoded by other ORFs at the 3' polyadenylated (Figure 3a). The HE protein is a glycoprotein with neuraminidase O-acetyl-esterase activity and the active site FGDS, is present downstream to ORF1a/b and upstream to S gene. The S protein is responsible for the characteristic crown-like appearance because of the spike present on the surface of CoVs and the most variable sequences for binding receptor and entry to the host cells. The E protein is a small hydrophobic integral membrane protein and critical for virus assembly. The M protein is associated with the envelope in all coronaviruses to induce membrane curvature. The N protein is a nonspecific RNA-binding protein that forms the ribonucleocapsid with viral genomic RNA⁷⁸⁻⁸⁰.

3.1 HCoV-229E and OC43

The RNA genome of HCoV-229E is about 27,240 nucleotides, with a poly(A) tail. The GC content is nearly 38%. The laboratory strains of HCoV-229E have eight putative protein-coding genes with the characteristic gene order ORF1a, ORF1b, HE, S, ORF4a, ORF4b, E, M, and N, while there are eight in the subsequent clinical strains present as an intact ORF4⁸¹⁻⁸³(Figure 3b). For HCoV-229E clinical strain, transcription regulatory sequence (TRS) motif is present in 3' end of the leader sequence and upstream of each structural gene. The TRS core structure is UCUCAACU for leader, S and E gene, UCUAACU for the M and N gene, and UCAACU for ORF4 gene. The first complete genome sequence of the HCoV-OC43 comprises 30,738 nucleotides, with a poly(A) tail. The GC content is 37%, with the characteristic gene order ORF1a, ORF1b, NS2a, HE, S, NS5a, E, M, and N^{48,84}(Figure 3b). HE protein reinforces the ability of HCoV-OC43 to infect because of its acetyl-esterase activity⁸⁵. The TRS core structure is UCUAAC for leader, NS2a and S gene, UCUAAC for the NS5a and E gene, UUAAC for HE gene, UCCAAC for M gene and UCUAAC for N gene⁸⁶.

3.2 HCoV-NL63 and HKU1

The HCoV-NL63 genome encompasses 27,553 nucleotides, with a poly(A) tail.

The GC content is 34%, very low GC contents among all HCoV. The genome order is ORF1a, ORF1b, S, ORF3, E, M, and N. Similar to HCoV-229E, only one ORF protein is located between the S and E genes^{87,88}. It was reported that the accessory gene was structural N-glycosylated and virion-incorporated for cell infection⁸⁹. The TRS core sequence of the virus is defined as AACUAAA for the most of ORFs except the E gene for which the TRS is 5'-AACUAUA-3'^{88,90}. The RNA genome of HCoV-HKU1 is about 29,926 nucleotides, with a poly(A) tail. HCoV-HKU1 has the lowest GC contents (32%) among all HCoVs. Similar to the genome organization of HCoV-OC43, the genome order is ORF1a, ORF1b, HE, S, ORF4, E, M, N and ORF8^{87,91} (Figure 3b). The TRS core sequence of HCoV-HKU1 is 5'-AAUCUAAAC-3' located upstream of all the ORFs except the E gene which may share the same TRS with ORF4¹⁷. Like HCoV-OC43, HE protein of HCoV-HKU1 may have an acetyl-esterase activity as receptor-destroying enzymes (RDE) by using sialic acids⁹².

3.3 SARS-CoV

The RNA genome of SARS-CoV encompasses 29,727 nucleotides, and the GC content is 41%, with a poly(A). The characteristic gene order of SARS-CoV is ORF1a, ORF1b, S, ORF3a, ORF3b, E, M, ORF6, ORF7a, ORF7b, ORF8a, ORF8b, N, ORF9a and ORF9b^{93,94}. The exact function of these nonstructural accessory proteins is unclear. The ORF8 protein sequences of SARS-CoV isolated from early-phase patients is full length²⁵. However, The ORF8 derived from the mid- and late-phase SARS-CoV infected patients contains ORF8a and 8b because of a 29-nucleotide deletion, which leads the split of complete ORF8 into putative ORF8a and 8b^{95,96}. Recently, Lau et al. revealed that the ORF8 protein of SARS-CoV, which was likely acquired from SL-CoVs by recombination, may be responsible for animal-to-human transmission⁹⁷. The N-glycosylation sites for ORF3a and ORF8b and O-glycosylation sites for ORF3a and ORF9b were predicted using the NetNGlyc server⁹⁸. A study found a putative TRS core leader sequence is 5'-CUAAAC-3' excluding ORF1a and ORF1b⁹³. Another group reported that 5'-AAACGAAC-3' (genomic nucleotides 65 to 72), was present upstream of ORF1a and five other ORFs but not including ORF1b and E⁹⁴. Soon, Thiel and colleagues isolated a conserved sequence (5'-ACGAAC-3') located in front of nine predicted ORFs (ORF1a, S, ORF3a, E, M, ORF6, ORF7a, ORF8a and N)^{99,100}.

3.4 MERS-CoV

The RNA genome of MERS-CoV is about 30,119 nucleotides in length and the GC content is 41%, with a poly(A) tail. The characteristic gene order of SARS-CoV is ORF1a, ORF1b, S, ORF3, ORF4a, ORF4b, ORF5, E, M, ORF8b, and N^{101,102}. Although the exact function of the accessory proteins including ORF3, ORF4a, ORF4b, ORF5 and ORF8b, is still unclear, these proteins have been reported to play an important role in viral replication. Deletion-mutants of ORF3, ORF4a, ORF4b, or ORF5 are attenuated for MERS-CoV replication *in vitro*^{103,104}. Further studies suggest that these accessory proteins are involved in evading the host immune system, such as ORF4a/4b and ORF5 proteins as strong IFN antagonists^{105,106}. The TRS core (5'-AACGAA-3') are located at the 3' end of the leader sequence and at different

positions upstream of genes in the genomic 3'-proximal domain of MERS-CoV¹⁰⁷.

3.5 SARS-CoV-2

The genome of SARS-CoV-2 is nearly 30,000 nucleotides, and the GC content is about 38%, with a poly(A). The characteristic gene order is ORF1a, ORF1b, S, ORF3a/3b, E, M, ORF6, ORF7a/7b, ORF8, N, ORF9a, ORF9b and ORF10^{32,108-110} (Figure 3b). As with SARS-CoV, SARS-CoV-2 has a predicted ORF8 gene, without known functional domain or motif, located between the M and N genes. But, the ORF8 genome sequences are more similar to those of bat SARSr-CoVs ZXC21 and ZC45 than ORF8 derived from SARS-CoV¹¹¹. A high conservation was observed for structural proteins E, M and A across the *Betacoronavirus* genus, while accessory proteins ORF8 seem to have much stricter evolutionary constraints¹¹². The ORF8 protein has a high possibility to form a protein with an alpha-helix, following with a beta-sheet containing six strands based on a secondary structure prediction¹¹¹. The TRS core structure of SARS-CoV-2 is CUA AAC for ORF1a/b, S, M, ORF8, N and ORF10 gene, ACG AAC for the ORF3, E, ORF6 and ORF7¹¹³. To date, high-resolution crystal structures of SARS-CoV-2 proteins, including PLpro, Mpro, RdRp and S proteins, have been determined by research groups from all over the world (Suppl table 1).

4. Receptor Recognition and Cell Entry

The S glycoprotein, which is responsible for the protruding “spikes” like a crown under electron microscopy, binds receptor of host cells and determines the species tropism. The S protein consists of two functionally regions: the S1 unit contains an N-terminal domain (NTD) and a C-terminal domain (CTD, namely RBD), whereas the S2 unit includes a transmembrane region, fusion peptide (FP), and heptad repeats (HR1 and HR2)^{114,115} (Figure 3c). The S proteins mediate attachment to the cellular receptors by RBD domain in S1 region and subsequent fusion of the virus-cell membrane by transmembrane fusion domain in S2 region^{116,117}. The difference in receptor usage among these coronaviruses is attributed to diversity in local architecture and receptor-binding site accessibility from S protein^{118,119}.

4.1 APN for HCoV-229E and ACE2 for HCoV-NL63

Aminopeptidase N (APN) is a type II glycoprotein that belongs to the family of membrane-bound metalloproteases. The APN glycoprotein is expressed in a variety of tissues, including epithelial cells from the renal proximal tubules, intestinal brush border and the respiratory tract, cells of the monocytic and granulocytic lineage, synaptic membranes of the central nervous system¹²⁰. Human aminopeptidase N (hAPN/CD13/ANPEP) is reported to be a receptor for HCoV-229E¹²¹. The RBD of HCoV-229E spike protein is located between residues 417 and 547¹²² (Table 1). Although HCoV-229E has been proved to take an endosomal pathway for cell entry¹²³, the virus preferred cell-surface TMPRSS2 to endosomal cathepsin to enter cell¹²⁴. Angiotensin converting enzyme 2 (ACE2) is a type I transmembrane protein that belongs to the angiotensin-converting enzyme family. ACE2 protein is expressed in various human organs, including lung alveolar epithelial cells, pneumocytes and enterocytes of the small intestine, and arterial and venous endothelial cells and

smooth muscle cells^{125,126}. HCoV-NL63 is found to employ ACE2 as a receptor for cellular entry in 2002¹²⁷. The minimal RBD of the HCoV-NL63 S protein is located between residues 476 and 616¹²⁸ (Table 1). HCoV-NL63 was observed to enter the cell by clathrin-mediated endocytosis¹²⁹.

4.2 9-*O*-Ac-Sia for HCoV-OC43 and HKU1

Sialic acids (Sias) are acidic nine-carbon sugars that commonly cap the glycan chains of cell surface glycoproteins and glycolipids. 9-*O*-acetylated sialic acid (9-*O*-Ac-Sia), as an attachment receptor determinant, can be carried by sialoglycan-based receptors¹³⁰. The S protein of HCoV-OC43 and HKU1 employ 9-*O*-Ac-Sia residues on glycoproteins to initiate the infection of host cells^{131,132}. The HE protein consists of two functional units: a corresponding sialate *O*-acetyl-esterase domain and an *O*-acetylated sialic acid binding domain¹³³. However, the HE protein of these two coronaviruses has not exhibited *O*-acetylated sialic acid binding activity¹³². In contrast, the HE protein possesses an acetyl-esterase activity recognized by the S protein, which plays a role as an RDE^{85,134}. In conclusion, HCoV-OC43 and HKU1 early utilize 9-*O*-Ac-Sia as a receptor determinant by the S protein to initiate the infection of host cells and late mediates sialate-*O*-acetyl-esterase RDE activity by the HE protein. Furthermore, the S protein of HCoV-OC43 and HKU1 was recently reported to bind 9-*O*-Ac-Sia via a domain A of S1 subunit (S1^A)^{135,136}. Similar to HCoV-229E, OC43 and HKU1 also liked the cell-surface TMRRSS2 rather than endosomal cathepsins for cell entry¹²⁴.

4.3 DPP4 for MERS-CoV

Dipeptidyl peptidase 4 (DPP4), which is known as CD26, is a cell surface glycoprotein of 110 kDa. As a type II transmembrane protein, DPP4 is ubiquitously expressed by a variety of cells and is cleaved of the cell membrane in a process called shedding¹³⁷. It is reported that DPP4 is a functional receptor for the MERS-CoV^{138,139}. The initial S protein RBD of MERS-CoV is located between residues 367 and 606¹⁴⁰ (Table 1). The MERS-CoV S1 domain contains a core structure and an accessory subdomain receptor-binding motif (RBM, residues 484–567) (Figure 3). The core structure is a five-stranded antiparallel β sheet (β 1, β 2, β 3, β 4 and β 9) with two short α helices in the connecting loops (α 1 and α 2). The RBM is a four-stranded antiparallel β sheet (β 5, β 6, β 7 and β 8)¹⁴¹ (Figure 4a and b). The flexible RBD region in MERS-CoV S proteins is located between residues 381 and 588, which is not contradictory to previous study. In addition, two states of the RBD (lying state and standing state) are captured by a high-resolution structure of the trimeric MERS-CoV S protein by cryo-EM. The dynamic RBD is facilitated to be recognized by DPP4¹⁴². MERS-CoV gains entry into host cells by direct fusion at the plasma membrane by TMRRSS2. In the absence of TMRRSS2, MERS-CoV is endocytosed, and can be triggered by cathepsin L to complete viral entry¹⁴³.

4.4 ACE2 for SARS-CoV

SARS-CoV utilizes ACE2 as its functional entry receptor, similar to HCoV-NL63¹⁴⁴. A minimal RBD, which is located in the S1 region (residues 306–527) (Table 1), has greater affinity to bind ACE2 than does a longer fragment (residues 12–672)^{145,146}. The SARS-CoV RBD also includes a core structure and an accessory

subdomain RBM (residues 424–494) in direct binding ACE2¹⁴⁵. The core subdomain is a five-stranded antiparallel β sheet (β 1, β 2, β 3, β 4 and β 7) with two short α helices in the connecting loops (α 1 and α 2). The RBM subdomain is a two-stranded antiparallel β sheet (β 5 and β 6) with two short connecting α helices (α 3 and α 4) in the loops^{141,147} (Figure 4c and d). Particularly, two sites in RBM (residues 479 and 487), are responsible for SARS disease progression and SARS-CoV tropism. Mutations in RBM residues 479 and 487 have an effect on transmission of SARS-CoV^{145,148}. A recent study reported that the flexible RBD region (residues 318–513) in SARS-CoV S protein presents two states of the RBD (lying state and standing state), similar to MERS-CoV mentioned previously¹⁴². A large of studies have proved that SARS-CoV use multiple pathways for host cell entry, including direct fusion with the plasma membrane by TMPRSS2, cathepsin L-mediated endocytosis, and clathrin- and caveolae-independent endocytosis¹⁴⁹⁻¹⁵².

4.5 ACE2 for SARS-CoV-2

ACE2 is the functional surface receptor for SARS-CoV-2 that is causing the COVID-19^{153,154}. ACE2 expression in human airway epithelial cells is enhanced by interferon and influenza, which could be exploited by SARS-CoV-2¹⁵⁵. Gut enterocytes was also infected by the novel coronavirus because of ACE2 high expression in the intestinal epithelium¹⁵⁶. SARS-CoV-2 has an RBD (residues 333–527) located in the S1 protein to engage ACE2, nearly identical to that of the SARS-CoV RBD (Table 1). The SARS-CoV-2 RBD also contains a core structure and an accessory subdomain RBM (residues 438–506) that interacts directly with ACE2¹⁵⁷. The core subdomain is a twisted four-stranded antiparallel β sheet (β 1, β 2, β 3 and β 6) with two short α helices in the connecting loops (α 1, α 2 and α 3). The RBM subdomain is a two-stranded antiparallel β sheet (β 4 and β 5) with two short connecting α helices (α 4 and α 5) in the loops¹⁵⁷ (Figure 4e and f). The overall amino acid sequence identities are around 76%-78% for the S protein, around 73%-76% for the RBD, and 50%-53% for the RBM between SARS-CoV-2 and SARS-CoV^{158,159}. A recent study uncovers cryo-EM structure of the full-length human ACE2, which presents two conformations (open and closed) of ACE2¹⁶⁰. SARS-CoV-2 RBD takes a more compact conformation than SARS-CoV RBD to bind ACE2, which enhances its ACE2-binding affinity¹⁶¹. Compared with SARS-CoV, ACE2 binding to SARS-CoV-2 S ectodomain has a 10- to 20-fold stronger affinity¹⁶². Another research group demonstrated that SARS-CoV-2 RBD binding to ACE2 displayed 4-fold higher affinity than the SARS-RBD and a mutation in ACE2 amino acid (K353) was sufficient to abolish the binding¹⁶³. A recent study reported that SARS-CoV-2 gained entry into cells via a new receptor CD147, suggesting the diversity of binding receptor for the virus¹⁶⁴. The cellular serine protease TMPRSS2 primes SARS-CoV-2 S for entry into host cells¹⁵⁴. Proprotein convertase furin preactivation of the SARS-CoV-2 S protein is helpful for cell entry and evading immune surveillance¹⁶⁵. The expression of ACE2 and TMPRSS2 is higher in nasal epithelial cells than other tissues, suggesting nasal epithelial cells are the loci of initial infection¹⁶⁶. Ou et al. recently revealed that SARS-CoV-2 invades hACE2 overexpressed 293 cells mainly through endocytosis¹⁶⁷.

5. Therapeutic Strategies for HCoVs

Currently, there are no clinical treatments or prevention strategies, such as approved antiviral drugs or vaccines, for highly pathogenic coronaviruses. Severe HCoV-infected patients mainly receive supportively medical care, along with different drugs combination treatments. Several strategies have been used to treat infections with SARS-CoV, MERS-CoV and SARS-CoV-2¹⁶⁸. This part summarizes the progress of therapeutic agents and vaccines for these three highly pathogenic coronaviruses caused diseases, as described below.

5.1 Virus targeted treatments.

Nucleoside analogues target the viral RdRp to block RNA synthesis and have a broad-spectrum activity against a wide range of CoVs^{169,170}. Ribavirin is a guanosine analogue with broad-spectrum activity against RNA viruses¹⁷¹. Although ribavirin was used to treat patients infected by SARS- and MERS- CoV, it may be associated with many side effects such as hemolytic anemia and cardiorespiratory distress at high doses⁸. So far it is unclear whether ribavirin treatment could improve the clinical outcome of COVID-19 disease. Remdesivir (GS-5734, Gilead Science) is a prodrug of the adenine derivative and broadly against MERS-CoV, SARS-CoV and Ebola virus¹⁷²⁻¹⁷⁴. A COVID-19 patient from the USA recovered after treatment with intravenous remdesivir¹⁷⁵. Soon a study demonstrated that remdesivir combined with chloroquine effectively suppresses SARS-CoV-2 in vitro¹⁷⁶. Two phase III trials have begun from February to April in 2020¹⁷⁷. Recent clinical data shown 68% severe COVID-19 patients (36/53) had an improvement in oxygen-support class after treatment with compassionate-use remdesivir¹⁷⁸. In addition, the cryo-EM structure of the RdRp complexed with a template-primer RNA and remdesivir has been determined¹⁷⁹. Lopinavir and ritonavir were protease inhibitors for HIV treatment initially¹⁸⁰. Lopinavir-ritonavir targeted coronavirus nonstructural protein 3CLpro and had antiviral activity against MERS-CoV and SARS-CoV^{181,182}. Clinical trials of lopinavir and ritonavir have been initiated in SARS-CoV-2 infected patients. However, a recent study shows that lopinavir–ritonavir treatment has not significantly accelerated clinical improvement, reduced mortality, or diminished viral RNA detectability in severe COVID-19 patients¹⁸³. EIDD-2801, a prodrug of EIDD-1931 (NHC), is a ribonucleoside analog with broad-spectrum activity against a variety of viruses such as influenza and Ebola. Sheahan et al. recently shown that EIDD-1931 is highly active against SARS-CoV-2 in primary human airway epithelial cell cultures and SARS- or MERS-CoV infected mice¹⁸⁴. To date, the crystal structures of SARS-CoV-2 RdRp and Mpro (3CLpro) have been reported, which is helpful for design of new antiviral drugs targeting RdRp and Mpro of coronaviruses¹⁸⁵⁻¹⁸⁸.

5.2 host targeted treatment.

The host innate interferon (IFN) response is crucial for the control of viral replication after infection, which can be augmented by the supplementation of recombinant interferons¹⁸⁹. A variety of IFN types have been administrated to patients with SARS- and MERS-CoV, typically in combination with broad-spectrum antivirals such as ribavirin or lopinavir–ritonavir. IFN α was proven to be effective in a small number of

cases in combination with ribavirin¹⁹⁰. IFN α 2a, IFN α 2b and IFN β 1b, in combinations with ribavirin or lopinavir–ritonavir, were also used to treat patients with MERS-CoV^{182,191,192}. However, IFNs are not recommended as first-line agents considering their side effects including anemia, fatigue and depression. Additionally, Blanco-Melo et al. recently found that interferons type I and III innate response to infection with SARS-CoV-2 is limited to inhibit virus replication¹⁹³. Corticosteroids act as immunomodulatory agents and have an anti-inflammatory effect. Corticosteroids in combinatory therapies with ribavirin or IFN had no favorable response in patients with MERS-CoV⁸. Although IFN α 1 plus corticosteroids was used to be treated SARS-CoV associated disease, it was reported that the SARS-CoV infected patient, who received prolonged treatment with corticosteroids treatment, died of aspergillosis^{194,195}. Furthermore, recent clinical study does not support corticosteroid treatment for COVID-19 patients with lung injury¹⁹⁶.

5.3 Antibody and plasma therapy.

Monoclonal antibodies (mAbs) have potentially therapeutic effects on combating highly pathogenic viral diseases, by neutralizing structural proteins on coronaviruses¹⁹⁷. Convalescent plasma or other preparations (monoclonal, hyperimmune globulin) that possess neutralizing antibodies have been the most worth consideration of therapies for SARS- and MERS-CoV^{198,199}. Although several studies found that mAbs targeting SARS- and MERS-CoV inhibited viral replication and ameliorated related disease in vitro or in animal models²⁰⁰⁻²⁰², large scale clinical trial involved in convalescent plasma or mAbs against SARS- and MERS-CoV are lacking²⁰³. Given the urgency of the 2019-nCoV outbreak and time-consuming for new interventions, it is worth to assess the existing neutralizing monoclonal antibody in the treatment of SARS- and MERS-CoV²⁰⁴. A SARS-CoV-specific human monoclonal antibody (CR3022) was first reported to have a potential binding with the RBD of SARS-CoV-2 (KD of 6.3 nM)²⁰⁵. The crystal structure of RBD complexed with CR3022 has shown that the drug targets a highly conserved epitope (Suppl table 1). Ju et al. recently reported the isolation of over 200 RBD-specific mAbs derived from COVID-19 patients and found two potent antibodies, P2C-1F11 and P2B-2F6, out-competed ACE2 with close to 100% efficiency²⁰⁶. Meanwhile, Shi et al. also isolated two human mAbs (CA1 and CB6) from a convalescent COVID-19 patient and found the latter inhibited SARS-CoV-2 infection in *rhesus macaques*, suggesting that it has significant potential to serve as a therapeutic agent for COVID-19²⁰⁷. A novel human monoclonal antibody (47D11) exhibited cross-neutralizing activity of SARS-CoV-2 and SARS-CoV by binding a conserved epitope on the spike RBD²⁰⁸. Wrapp et al. described that single-domain camelid antibodies can neutralize pathogenic *Betacoronaviruses* including emerging SARS-CoV-2²⁰⁹. Hence, convalescent plasma, which is from COVID-19 patients who have recovered, and monoclonal antibody offer the possibility of prevention and therapy for emerging coronaviruses caused diseases including COVID-19 in the future²¹⁰. Besides, a recent study demonstrated that clinical grade human recombinant soluble ACE2 can inhibit SARS-CoV-2 infection in Vero-E6 cells and human capillary and kidney organoids, suggesting a new approach to prevent SARS-CoV-2 infection²¹¹.

5.4 Vaccines.

Vaccines are considered the gold standard for highly pathogenic coronaviruses prevention and treatment. There are no currently approved vaccines for human coronaviruses caused infection, because of the requirement of many years' efforts to develop a new vaccine²¹²⁻²¹⁴. Multiple vaccination strategies targeting SARS- and MERS-CoV are in the early stages, including inactivated virus vaccines, live-attenuated virus vaccines, viral vector vaccines, subunit vaccines and DNA/protein vaccines^{215,216}. To date, more than 300 vaccine developments disclose the potential methodologies to treat and prevent coronavirus caused infections including COVID-19¹⁶⁸. An animal model is necessary for vaccine development to test the effectiveness of vaccines in vivo. Bao et al. established a mouse model by using the hACE2 transgenic animal infected by SARS-CoV-2, which may facilitate the development of vaccines against the virus²¹⁷. Another animal model has been reported that *rhesus macaques* was infected using SARS-CoV-2 isolated from clinical bronchoalveolar lavage fluid. *Rhesus macaques* infected by SARS-CoV-2 showed acute localized-to-widespread pneumonia already reported in COVID-19 patients, without obvious clinical symptoms of respiratory disease²¹⁸. Meanwhile, another research group found that conjunctival infected-*rhesus macaques* presented high viral load and distribution in the nasolacrimal system²¹⁹. Recently, Rockx et al. found SARS-CoV-2 causes COVID-19-like disease in *cynomolgus macaques*²²⁰. These animal models are especially important for testing preventive and therapeutic strategies including broad vaccines and drugs against highly pathogenic coronaviruses. Gao et al. recently developed an inactivated vaccine and found its protective immunity and neutralization activities against the novel coronavirus in *rhesus macaques*²²¹. To date, the first COVID-19 vaccine, which is a recombinant adenovirus type-5 (Ad5) vectored COVID-19 vaccine expressing the S protein of SARS-CoV-2, underwent a phase 1 clinical trial and was found to be safe, well-tolerated and able to generate an immune response against SARS-CoV-2 in humans²²².

6. Outlook and conclusions

In the first 20 years of this century, we have witnessed three outbreaks of previously unknown highly pathogenic coronaviruses, SARS-CoV, MERS-CoV and SARS-CoV-2. COVID-19 caused by the novel coronavirus has become a global pandemic and is still continuing presently. The collected data focus on understanding the pathology and epidemiology of human coronaviruses, including pathogen transmission, the reservoir and/or intermediate hosts, and virus biology. Before the next emergency of a novel highly pathogenic coronavirus, there are many lessons still to be learned for us. For prevention, the broad-spectrum, pan-coronavirus vaccines should be developed. To prevent virus of zoonotic sources from getting into the human population, the barriers between natural reservoirs and human society must be maintained. For diagnosis, the rapid identification of the full-length genome of emerging novel coronavirus by next-generation meta-transcriptomic sequencing made it possible to design quick and accurate diagnostic assays. Zhang et al. recently developed an AI system to quickly diagnose SARS-CoV-2 by using Computed

Tomography (CT)²²³. For isolation, the most effective way to prevent infections and save lives is breaking human-to-human transmission. A recent report summarizes five different non-pharmaceutical interventions, including case isolation in the home, voluntary home quarantine, social distancing of those over 70 years old, social distancing of entire population, and closure of schools and universities²²⁴. For therapies, with the development of high-resolution crystal structures of coronavirus proteins (Suppl table 1) and the establishment of animal models aiming at coronaviruses, developing pan-CoV antiviral drugs against current and future emerging coronaviruses have become the ultimate therapeutic strategies.

The continuing epidemic threat of SARS-CoV-2 to global health told us that humans live in a “Global Village,” where an infectious disease emerging in any corner of the world has the potential to disseminate globally. In mind of “One Health, One World”, we should foster collaborative and multisectoral effects of trans-disciplines to achieve optimal health for people, animals, and the environment²²⁵.

References

- 1 Peiris, J. S. M., Phil., D., Yuen, K. Y., Osterhaus, A. D. M. E. & Stöhr, K. The severe acute respiratory syndrome. *N Engl J Med* **349**, 2431-2441 (2003).
- 2 Zaki, A. M., van Boheemen, S., Bestebroer, T. M., Osterhaus, A. D. & Fouchier, R. A. Isolation of a novel coronavirus from a man with pneumonia in Saudi Arabia. *N Engl J Med* **367**, 1814-1820, doi:10.1056/NEJMoa1211721 (2012).
- 3 Wang, C., Horby, P. W., Hayden, F. G. & Gao, G. F. A novel coronavirus outbreak of global health concern. *The Lancet* **395**, 470-473, doi:10.1016/s0140-6736(20)30185-9 (2020).
- 4 Kupferschmidt, K. & Cohen, J. Will novel virus go pandemic or be contained? *Science* **367**, 610-611 (2020).
- 5 Su, S. *et al.* Epidemiology, genetic recombination, and pathogenesis of coronaviruses. *Trends Microbiol* **24**, 490-502, doi:10.1016/j.tim.2016.03.003 (2016).

- 6 Zhu, N. *et al.* A novel coronavirus from patients with pneumonia in China, 2019. *N Engl J Med* **382**, 727-733, doi:10.1056/NEJMoa2001017 (2020).
- 7 Tang, B. *et al.* An updated estimation of the risk of transmission of the novel coronavirus (2019-nCov). *Infect Dis Model* **5**, 248-255, doi:10.1016/j.idm.2020.02.001 (2020).
- 8 Zumla, A., Chan, J. F., Azhar, E. I., Hui, D. S. & Yuen, K. Y. Coronaviruses - drug discovery and therapeutic options. *Nat Rev Drug Discov* **15**, 327-347, doi:10.1038/nrd.2015.37 (2016).
- 9 Cunningham, C. & Stuart, H. Cultivation of the virus of infectious bronchitis of chickens in embryonated chicken eggs. *Am J Vet Res* **8**, 209-212 (1947).
- 10 Steffen, I. & Simmons, G. Coronaviruses. *eLS*, 1-9, doi:10.1002/9780470015902.a0023611 (2015).
- 11 Cong, Y., Verlhac, P. & Reggiori, F. The interaction between nidovirales and autophagy components. *Viruses* **9**, 182-196, doi:10.3390/v9070182 (2017).
- 12 Myint, S. Human coronaviruses: a brief review. *Rev Med Virol* **4**, 35-46, doi:10.1002/rmv.1980040108 (1994).
- 13 Hamre, D. & Procknow, J. A new virus isolated from the human respiratory tract. *Proc Soc Exp Biol Med* **121**, 190-193, doi:10.3181/00379727-121-30734 (1966).
- 14 McIntosh, K., Dees, J., Becker, W. B., Kapikian, A. Z. & Chanock, R. M. Recovery in tracheal organ cultures of novel viruses from patients with respirator disease. *Proc Natl Acad Sci U S A* **57**, 933-940, doi:10.1073/pnas.57.4.933 (1967).
- 15 van der Hoek, L., Pyrc, K. & Berkhout, B. Human coronavirus NL63, a new respiratory

- virus. *FEMS Microbiol Rev* **30**, 760-773, doi:10.1111/j.1574-6976.2006.00032.x (2006).
- 16 van der hoek, L. *et al.* Identification of a new coronavirus. *Nat. Med* **10**, 368-373, doi:10.1038/nm1024 (2004).
- 17 Woo, P. C. *et al.* Characterization and complete genome sequence of a novel coronavirus, coronavirus HKU1, from patients with pneumonia. *J Virol* **79**, 884-895, doi:10.1128/JVI.79.2.884-895.2005 (2005).
- 18 Dijkman, R. *et al.* Isolation and characterization of current human coronavirus strains in primary human epithelial cell cultures reveal differences in target cell tropism. *J Virol* **87**, 6081-6090, doi:10.1128/JVI.03368-12 (2013).
- 19 Woo, P. C., Lau, S. K., Yip, C. C., Huang, Y. & Yuen, K. Y. More and more coronaviruses: human coronavirus HKU1. *Viruses* **1**, 57-71, doi:10.3390/v1010057 (2009).
- 20 Jsm, P. *et al.* Coronavirus as a possible cause of severe acute respiratory syndrome. *The Journal of Tepecik Education and Research Hospital* **13**, 55-56, doi:10.5222/terh.2003.26734 (2003).
- 21 Drosten, C. *et al.* Identification of a novel coronavirus in patients with severe acute respiratory syndrome. *N Engl J Med* **348**, 1967-1976, doi:10.1056/NEJMoa030747 (2003).
- 22 Ksiazek, T. G. *et al.* A novel coronavirus associated with severe acute respiratory syndrome. *N Engl J Med* **348**, 1953-1966, doi:10.1056/NEJMoa030781 (2003).
- 23 Lee, N. *et al.* A major outbreak of severe acute respiratory syndrome in Hong Kong. *N*

- Engl J Med* **348**, 1986-1994, doi:10.1056/NEJMoa030685 (2003).
- 24 Wang, M. *et al.* SARS-CoV infection in a restaurant from palm civet. *Emerg Infect Dis* **11**, 1860-1865, doi:10.3201/eid1112.041293 (2006).
- 25 Song, H.-D. *et al.* Cross-host evolution of severe acute respiratory syndrome coronavirus in palm civet and human. *Proc Natl Acad Sci U S A* **102**, 2430-2435, doi:10.1073/pnas.0409608102 (2005).
- 26 Haagmans, B. L. *et al.* Middle East respiratory syndrome coronavirus in dromedary camels: an outbreak investigation. *Lancet Infect Dis* **14**, 140-145, doi:10.1016/s1473-3099(13)70690-x (2014).
- 27 Huang, C. *et al.* Clinical features of patients infected with 2019 novel coronavirus in Wuhan, China. *The Lancet* **395**, 497-506, doi:10.1016/s0140-6736(20)30183-5 (2020).
- 28 Gralinski, L. E. & Menachery, V. D. Return of the coronavirus: 2019-nCoV. *Viruses* **12**, 135-143, doi:10.3390/v12020135 (2020).
- 29 Zhang, H. Early lessons from the frontline of the 2019-nCoV outbreak. *The Lancet* **395**, 687, doi:10.1016/s0140-6736(20)30356-1 (2020).
- 30 Xu, Y. *et al.* Characteristics of pediatric SARS-CoV-2 infection and potential evidence for persistent fecal viral shedding. *Nat Med*, doi:10.1038/s41591-020-0817-4 (2020).
- 31 Munster, V. J., Koopmans, M., van Doremalen, N., van Riel, D. & de Wit, E. A novel coronavirus emerging in China - key questions for impact assessment. *N Engl J Med* **382**, 692-694, doi:10.1056/NEJMp2000929 (2020).
- 32 Wu, F. *et al.* A new coronavirus associated with human respiratory disease in China.

- Nature* **579**, 265-269, doi:10.1038/s41586-020-2008-3 (2020).
- 33 Coronaviridae Study Group of the International Committee on Taxonomy of, V. The species severe acute respiratory syndrome-related coronavirus: classifying 2019-nCoV and naming it SARS-CoV-2. *Nat Microbiol* **5**, 536-544, doi:10.1038/s41564-020-0695-z (2020).
- 34 Chan, J. F.-W. *et al.* A familial cluster of pneumonia associated with the 2019 novel coronavirus indicating person-to-person transmission: a study of a family cluster. *The Lancet* **395**, 514-523, doi:10.1016/s0140-6736(20)30154-9 (2020).
- 35 Tian, H. *et al.* An investigation of transmission control measures during the first 50 days of the COVID-19 epidemic in China. *Science* **31**, eabb6105, doi:10.1126/science.abb6105 (2020).
- 36 Cui, J., Li, F. & Shi, Z. L. Origin and evolution of pathogenic coronaviruses. *Nat Rev Microbiol* **17**, 181-192, doi:10.1038/s41579-018-0118-9 (2019).
- 37 Fan, Y., Zhao, K., Shi, Z. L. & Zhou, P. Bat coronaviruses in China. *Viruses* **11**, 210-224, doi:10.3390/v11030210 (2019).
- 38 Hu, B., Ge, X., Wang, L. F. & Shi, Z. Bat origin of human coronaviruses. *Virology* **12**, 221-231, doi:10.1186/s12985-015-0422-1 (2015).
- 39 Banerjee, A., Kulcsar, K., Misra, V., Frieman, M. & Mossman, K. Bats and coronaviruses. *Viruses* **11**, 41-56, doi:10.3390/v11010041 (2019).
- 40 Li, W. *et al.* Bats are natural reservoirs of SARS-like coronaviruses. *Science* **310**, 676-679, doi:10.1126/science.1118391 (2005).
- 41 Corman, V. M., Muth, D., Niemeyer, D. & Drosten, C. Hosts and sources of endemic

- human coronaviruses. *Adv Virus Res* **100**, 163-188, doi:10.1016/bs.aivir.2018.01.001 (2018).
- 42 Pfefferle, S. *et al.* Distant relatives of severe acute respiratory syndrome coronavirus and close relatives of human coronavirus 229E in bats, Ghana. *Emerg Infect Dis* **15**, 1377-1384, doi:10.3201/eid1509.090224 (2009).
- 43 Corman, V. M. *et al.* Evidence for an ancestral association of human coronavirus 229E with bats. *J Virol* **89**, 11858-11870, doi:10.1128/JVI.01755-15 (2015).
- 44 Tao, Y. *et al.* Surveillance of bat coronaviruses in Kenya identifies relatives of human coronaviruses NL63 and 229E and their recombination history. *J Virol* **91**, e01953, doi:10.1128/JVI.01953-16 (2017).
- 45 Huynh, J. *et al.* Evidence supporting a zoonotic origin of human coronavirus strain NL63. *J Virol* **86**, 12816-12825, doi:10.1128/JVI.00906-12 (2012).
- 46 Lau, S. K. *et al.* Discovery of a novel coronavirus, China Rattus coronavirus HKU24, from Norway rats supports the murine origin of Betacoronavirus 1 and has implications for the ancestor of Betacoronavirus lineage A. *J Virol* **89**, 3076-3092, doi:10.1128/JVI.02420-14 (2015).
- 47 Wang, W. *et al.* Discovery, diversity and evolution of novel coronaviruses sampled from rodents in China. *Virology* **474**, 19-27, doi:10.1016/j.virol.2014.10.017 (2015).
- 48 Vijgen, L. *et al.* Complete genomic sequence of human coronavirus OC43: molecular clock analysis suggests a relatively recent zoonotic coronavirus transmission event. *J Virol* **79**, 1595-1604, doi:10.1128/JVI.79.3.1595-1604.2005 (2005).
- 49 Vijgen, L. *et al.* Evolutionary history of the closely related group 2 coronaviruses:

- porcine hemagglutinating encephalomyelitis virus, bovine coronavirus, and human coronavirus OC43. *J Virol* **80**, 7270-7274, doi:10.1128/JVI.02675-05 (2006).
- 50 Guan, Y. *et al.* Isolation and characterization of viruses related to the SARS coronavirus from animals in southern China. *Science* **302**, 276-278, doi:10.1126/science.1087139 (2003).
- 51 Tu, C. *et al.* Antibodies to SARS coronavirus in civets. *Emerg Infect Dis* **10**, 2244-2248, doi:10.3201/eid1012.040520 (2004).
- 52 Lau, S. *et al.* Severe acute respiratory syndrome coronavirus-like virus in Chinese horseshoe bats. *Proc Natl Acad Sci U S A* **102**, 14040-14045, doi:10.1073/pnas.0506735102 (2005).
- 53 Ge, X. Y. *et al.* Isolation and characterization of a bat SARS-like coronavirus that uses the ACE2 receptor. *Nature* **503**, 535-538, doi:10.1038/nature12711 (2013).
- 54 Alagaili, A. N. *et al.* Middle East respiratory syndrome coronavirus infection in dromedary camels in Saudi Arabia. *mBio* **5**, e00884, doi:10.1128/mBio.00884-14 (2014).
- 55 Briese, T. *et al.* Middle East respiratory syndrome coronavirus quasispecies that include homologues of human isolates revealed through whole-genome analysis and virus cultured from dromedary camels in Saudi Arabia. *mBio* **5**, e01146, doi:10.1128/mBio.01146-14 (2014).
- 56 Reusken, C. B. E. M. *et al.* Middle East respiratory syndrome coronavirus neutralising serum antibodies in dromedary camels: a comparative serological study. *Lancet Infect Dis* **13**, 859-866, doi:10.1016/s1473-3099(13)70164-6 (2013).

- 57 Perera, R. A. P. M. *et al.* Seroepidemiology for MERS coronavirus using microneutralisation and pseudoparticle virus neutralisation assays reveal a high prevalence of antibody in dromedary camels in Egypt, June 2013. *Euro Surveill* **18**, 20574-20581, doi:10.2807/1560-7917.ES2013.18.36.20574 (2013).
- 58 Corman, V. M. *et al.* Antibodies against MERS coronavirus in dromedary camels, Kenya, 1992-2013. *Emerg Infect Dis* **20**, 1319-1322, doi:10.3201/eid2008.140596 (2014).
- 59 Memish, Z. A. *et al.* Middle East respiratory syndrome coronavirus in bats, Saudi Arabia. *Emerg Infect Dis* **19**, 1819-1823, doi:10.3201/eid1911.131172 (2013).
- 60 Anthony, S. J. *et al.* Further evidence for bats as the evolutionary source of middle east respiratory syndrome Coronavirus. *mBio* **8**, e00373, doi:10.1128/mBio.00373-17 (2017).
- 61 Chastel, C. Middle East respiratory syndrome (MERS): bats or dromedary, which of them is responsible? *Bull Soc Pathol Exot* **107**, 69-73, doi:10.1007/s13149-014-0333-1 (2014).
- 62 Wong, A. C. P., Li, X., Lau, S. K. P. & Woo, P. C. Y. Global epidemiology of bat coronaviruses. *Viruses* **11**, doi:10.3390/v11020174 (2019).
- 63 Woo, P. C., Lau, S. K., Li, K. S., Tsang, A. K. & Yuen, K. Y. Genetic relatedness of the novel human group C betacoronavirus to Tylonycteris bat coronavirus HKU4 and Pipistrellus bat coronavirus HKU5. *Emerg Microbes Infect* **1**, e35, doi:10.1038/emi.2012.45 (2012).
- 64 Yang, L. *et al.* MERS-related betacoronavirus in *Vespertilio superans* bats, China.

- Emerg Infect Dis* **20**, 1260-1262, doi:10.3201/eid2007.140318 (2014).
- 65 Annan, A. *et al.* Human betacoronavirus 2c EMC/2012-related viruses in bats, Ghana and Europe. *Emerg Infect Dis* **19**, 456-459, doi:10.3201/eid1903.121503 (2013).
- 66 Chu, D. K. W. *et al.* MERS coronaviruses from camels in Africa exhibit region-dependent genetic diversity. *Proc Natl Acad Sci U S A* **115**, 3144-3149, doi:10.1073/pnas.1718769115 (2018).
- 67 Zhou, P. *et al.* A pneumonia outbreak associated with a new coronavirus of probable bat origin. *Nature* **579**, 270-273, doi:10.1038/s41586-020-2012-7 (2020).
- 68 Tang, X. *et al.* On the origin and continuing evolution of SARS-CoV-2. *National Science Review*, doi:10.1093/nsr/nwaa036 (2020).
- 69 Zhang, Y. Z. & Holmes, E. C. A genomic perspective on the origin and emergence of SARS-CoV2. *Cell*, doi:10.1016/j.cell.2020.03.035 (2020).
- 70 Coutard, B. *et al.* The spike glycoprotein of the new coronavirus 2019-nCoV contains a furin-like cleavage site absent in CoV of the same clade. *Antiviral Res* **176**, 104742-104747, doi:10.1016/j.antiviral.2020.104742 (2020).
- 71 Paraskevis, D. *et al.* Full-genome evolutionary analysis of the novel corona virus (2019-nCoV) rejects the hypothesis of emergence as a result of a recent recombination event. *Infect Genet Evol* **79**, 104212-104216, doi:10.1016/j.meegid.2020.104212 (2020).
- 72 Patiño-Galindo, J. Á., Filip, I., AlQuraishi, M. & Rabadan, R. Recombination and convergent evolution led to the emergence of 2019 Wuhan coronavirus *bioRxiv*, doi:10.1101/2020.02.10.942748 (2020).

- 73 Xiao, K. *et al.* Isolation of SARS-CoV-2-related coronavirus from Malayan pangolins. *Nature*, doi:10.1038/s41586-020-2313-x (2020).
- 74 Liu, P. *et al.* Are pangolins the intermediate host of the 2019 novel coronavirus (SARS-CoV-2)? *PLoS Pathogens* **16**, e1008421, doi:10.1371/journal.ppat.1008421 (2020).
- 75 Lam, T. T.-Y. *et al.* Identifying SARS-CoV-2 related coronaviruses in Malayan pangolins. *Nature*, doi:10.1038/s41586-020-2169-0 (2020).
- 76 Liu, P., Chen, W. & Chen, J. P. Viral metagenomics revealed sendai virus and coronavirus infection of Malayan pangolins (*Manis javanica*). *Viruses* **11**, 979-994, doi:10.3390/v111110979 (2019).
- 77 Gaudin, T. J., Emry, R. J. & Wible, J. R. The phylogeny of living and extinct pangolins (mammalia, pholidota) and associated taxa: a morphology based analysis. *J Mamm Evol* **16**, 235-305, doi:10.1007/s10914-009-9119-9 (2009).
- 78 Chen, Y., Liu, Q. & Guo, D. Emerging coronaviruses: Genome structure, replication, and pathogenesis. *J Med Virol* **92**, 418-423, doi:10.1002/jmv.25681 (2020).
- 79 Woo, P. C., Huang, Y., Lau, S. K. & Yuen, K. Y. Coronavirus genomics and bioinformatics analysis. *Viruses* **2**, 1804-1820, doi:10.3390/v2081803 (2010).
- 80 Perlman, S. & Netland, J. Coronaviruses post-SARS: update on replication and pathogenesis. *Nat Rev Microbiol* **7**, 439-450, doi:10.1038/nrmicro2147 (2009).
- 81 Dijkman, R. *et al.* Human coronavirus 229E encodes a single ORF4 protein between the spike and the envelope genes. *Virology* **3**, 106-114, doi:10.1186/1743-422X-3-106 (2006).

- 82 Thiel, V., Herold, J., Schelle, B. & Siddell, S. Infectious RNA transcribed in vitro from a cDNA copy of the human coronavirus genome cloned in vaccinia virus. *J Gen Virol* **82**, 1273-1281, doi:10.1099/0022-1317-82-6-1273 (2001).
- 83 Farsani, S. M. *et al.* The first complete genome sequences of clinical isolates of human coronavirus 229E. *Virus Genes* **45**, 433-439, doi:10.1007/s11262-012-0807-9 (2012).
- 84 Lau, S. K. *et al.* Molecular epidemiology of human coronavirus OC43 reveals evolution of different genotypes over time and recent emergence of a novel genotype due to natural recombination. *J Virol* **85**, 11325-11337, doi:10.1128/JVI.05512-11 (2011).
- 85 Desforges, M., Desjardins, J., Zhang, C. & Talbot, P. J. The acetyl-esterase activity of the hemagglutinin-esterase protein of human coronavirus OC43 strongly enhances the production of infectious virus. *J Virol* **87**, 3097-3107, doi:10.1128/JVI.02699-12 (2013).
- 86 St-Jean, J. R. *et al.* Human respiratory coronavirus OC43: genetic stability and neuroinvasion. *J Virol* **78**, 8824-8834, doi:10.1128/JVI.78.16.8824-8834.2004 (2004).
- 87 Pyrc, K., Berkhout, B. & van der Hoek, L. The novel human coronaviruses NL63 and HKU1. *J Virol* **81**, 3051-3057, doi:10.1128/JVI.01466-06 (2007).
- 88 Abdul-Rasool, S. & Fielding, B. Understanding human coronavirus HCoV-NL63. *Open Virol J* **4**, 76-84, doi:10.2174/1874357901004010076 (2010).
- 89 Müller, M. *et al.* Human Coronavirus NL63 Open Reading Frame 3 encodes a virion-incorporated N-glycosylated membrane protein. *Virol J* **7**, 6-18, doi:10.1186/1743-422X-7-6 (2010).

- 90 Pyrc, K., Jebbink, M. F., Berkhout, B. & van der Hoek, L. Genome structure and transcriptional regulation of human coronavirus NL63. *Virology* **1**, 7-18, doi:10.1186/1743-422X-1-7 (2004).
- 91 Dominguez, S. R. *et al.* Isolation, propagation, genome analysis and epidemiology of HKU1 betacoronaviruses. *J Gen Virol* **95**, 836-848, doi:10.1099/vir.0.059832-0 (2014).
- 92 Forni, D., Cagliani, R., Clerici, M. & Sironi, M. Molecular evolution of human coronavirus genomes. *Trends Microbiol* **25**, 35-48, doi:10.1016/j.tim.2016.09.001 (2017).
- 93 Marra, M. A. *et al.* The genome sequence of the SARS-associated coronavirus. *Science* **300**, 1399-1404, doi:10.1126/science.1085953 (2003).
- 94 Rota, P. A. *et al.* Characterization of a novel coronavirus associated with severe acute respiratory syndrome. *Science* **300**, 1394-1399, doi:10.1126/science.1085952 (2003).
- 95 Oostra, M., de Haan, C. A. & Rottier, P. J. The 29-nucleotide deletion present in human but not in animal severe acute respiratory syndrome coronaviruses disrupts the functional expression of open reading frame 8. *J Virol* **81**, 13876-13888, doi:10.1128/JVI.01631-07 (2007).
- 96 Hilgenfeld, R. & Peiris, M. From SARS to MERS: 10 years of research on highly pathogenic human coronaviruses. *Antiviral Res* **100**, 286-295, doi:10.1016/j.antiviral.2013.08.015 (2013).
- 97 Lau, S. K. *et al.* Severe acute respiratory syndrome (SARS) coronavirus ORF8 protein is acquired from SARS-related coronavirus from greater horseshoe bats through recombination. *J Virol* **89**, 10532-10547, doi:10.1128/JVI.01048-15 (2015).

- 98 Stadler, K. *et al.* SARS--beginning to understand a new virus. *Nat Rev Microbiol* **1**, 209-218, doi:10.1038/nrmicro775 (2003).
- 99 Thiel, V. *et al.* Mechanisms and enzymes involved in SARS coronavirus genome expression. *J Gen Virol* **84**, 2305-2315, doi:10.1099/vir.0.19424-0 (2003).
- 100 Snijder, E. J. *et al.* Unique and conserved features of genome and proteome of SARS-coronavirus, an early split-off Ffrom the coronavirus group 2 lineage. *J Mol Biol* **331**, 991-1004, doi:10.1016/s0022-2836(03)00865-9 (2003).
- 101 Cotten, M. *et al.* Transmission and evolution of the Middle East respiratory syndrome coronavirus in Saudi Arabia: a descriptive genomic study. *The Lancet* **382**, 1993-2002, doi:10.1016/s0140-6736(13)61887-5 (2013).
- 102 Woo, P. C. *et al.* Novel betacoronavirus in dromedaries of the Middle East, 2013. *Emerg Infect Dis* **20**, 560-572, doi:10.3201/eid2004.131769 (2014).
- 103 Scobey, T. *et al.* Reverse genetics with a full-length infectious cDNA of the Middle East respiratory syndrome coronavirus. *Proc Natl Acad Sci U S A* **110**, 16157-16162, doi:10.1073/pnas.1311542110 (2013).
- 104 Almazan, F. *et al.* Engineering a replication-competent, propagation-defective Middle East respiratory syndrome coronavirus as a vaccine candidate. *mBio* **4**, e00650, doi:10.1128/mBio.00650-13 (2013).
- 105 Yang, Y. *et al.* The structural and accessory proteins M, ORF 4a, ORF 4b, and ORF 5 of Middle East respiratory syndrome coronavirus (MERS-CoV) are potent interferon antagonists. *Protein Cell* **4**, 951-961, doi:10.1007/s13238-013-3096-8 (2013).
- 106 Canton, J. *et al.* MERS-CoV 4b protein interferes with the NF-kappaB-dependent

- innate immune response during infection. *PLoS Pathog* **14**, e1006838, doi:10.1371/journal.ppat.1006838 (2018).
- 107 van Boheemen, S. *et al.* Genomic characterization of a newly discovered coronavirus associated with acute respiratory distress syndrome in humans. *mBio* **3**, e00473, doi:10.1128/mBio.00473-12 (2012).
- 108 Cui, H. *et al.* Structural genomics and interactomics of 2019 Wuhan novel coronavirus, 2019-nCoV, indicate evolutionary conserved functional regions of viral proteins. *bioRxiv*, doi:10.1101/2020.02.10.942136 (2020).
- 109 Taiaroa, G. *et al.* Direct RNA sequencing and early evolution of SARS-CoV-2. *bioRxiv*, doi:10.1101/2020.03.05.976167 (2020).
- 110 Wu, A. *et al.* Genome composition and divergence of the novel coronavirus (2019-nCoV) originating in China. *Cell Host Microbe* **27**, 325-328, doi:10.1016/j.chom.2020.02.001 (2020).
- 111 Chan, J. F. *et al.* Genomic characterization of the 2019 novel human-pathogenic coronavirus isolated from a patient with atypical pneumonia after visiting Wuhan. *Emerg Microbes Infect* **9**, 221-236, doi:10.1080/22221751.2020.1719902 (2020).
- 112 Ceraolo, C. & Giorgi, F. M. Genomic variance of the 2019-nCoV coronavirus. *J Med Virol* **92**, 522-528, doi:10.1002/jmv.25700 (2020).
- 113 Wu, F. *et al.* A new coronavirus associated with human respiratory disease in China. *Nature* **579**, 265-269, doi:10.1038/s41586-020-2008-3 (2020).
- 114 Kirchdoerfer, R. N. *et al.* Pre-fusion structure of a human coronavirus spike protein. *Nature* **531**, 118-121, doi:10.1038/nature17200 (2016).

- 115 Li, F. Receptor recognition mechanisms of coronaviruses: a decade of structural studies. *J Virol* **89**, 1954-1964, doi:10.1128/JVI.02615-14 (2015).
- 116 Alsaadi, E. & Jones, I. Membrane binding proteins of coronaviruses. *Future Virology* **14**, 275-286, doi:10.2217/fvl-2018-0144 (2019).
- 117 Walls, A. C. *et al.* Unexpected receptor functional mimicry elucidates activation of coronavirus fusion. *Cell* **176**, 1026-1039, doi:10.1016/j.cell.2018.12.028 (2019).
- 118 Gallagher, T. & Perlman, S. Public health: Broad reception for coronavirus. *Nature* **495**, 176-177, doi:10.1038/495176a (2013).
- 119 Walls, A. C. *et al.* Cryo-electron microscopy structure of a coronavirus spike glycoprotein trimer. *Nature* **531**, 114-117, doi:10.1038/nature16988 (2016).
- 120 Kolb, A., Hegyi, A. & Siddell, S. Identification of residues critical for the human coronavirus 229E receptor function of human aminopeptidase N. *J Gen Virol* **78**, 2795-2802, doi:10.1099/0022-1317-78-11-2795 (1997).
- 121 Yeager, C. *et al.* Human aminopeptidase N is a receptor for human coronavirus 229E. *Nature* **357**, 420-422, doi:10.1038/357420a0 (1992).
- 122 Bonavia, A., Zelus, B. D., Wentworth, D. E., Talbot, P. J. & Holmes, K. V. Identification of a receptor-binding domain of the spike glycoprotein of human coronavirus HCoV-229E. *J Virol* **77**, 2530-2538, doi:10.1128/jvi.77.4.2530-2538.2003 (2003).
- 123 Shirato, K., Kanou, K., Kawase, M. & Matsuyama, S. Clinical isolates of human coronavirus 229E bypass the endosome for cell entry. *J Virol* **91**, e01387, doi:10.1128/JVI.01387-16 (2017).
- 124 Shirato, K., Kawase, M. & Matsuyama, S. Wild-type human coronaviruses prefer

- cell-surface TMPRSS2 to endosomal cathepsins for cell entry. *Virology* **517**, 9-15, doi:10.1016/j.virol.2017.11.012 (2018).
- 125 Hamming, I. *et al.* Tissue distribution of ACE2 protein, the functional receptor for SARS coronavirus. A first step in understanding SARS pathogenesis. *J Pathol* **203**, 631-637, doi:10.1002/path.1570 (2004).
- 126 Kuba, K. *et al.* A crucial role of angiotensin converting enzyme 2 (ACE2) in SARS coronavirus-induced lung injury. *Nat Med* **11**, 875-879, doi:10.1038/nm1267 (2005).
- 127 Hofmann, H. *et al.* Human coronavirus NL63 employs the severe acute respiratory syndrome coronavirus receptor for cellular entry. *Proc Natl Acad Sci U S A* **102**, 7988-7993, doi:10.1073/pnas.0409465102 (2005).
- 128 Lin, H. X. *et al.* Identification of residues in the receptor-binding domain (RBD) of the spike protein of human coronavirus NL63 that are critical for the RBD-ACE2 receptor interaction. *J Gen Virol* **89**, 1015-1024, doi:10.1099/vir.0.83331-0 (2008).
- 129 Milewska, A. *et al.* Entry of human coronavirus NL63 into the cell. *J Virol* **92**, e01933, doi:10.1128/JVI.01933-17 (2017).
- 130 Baumann, A. M. *et al.* 9-O-Acetylation of sialic acids is catalysed by CASD1 via a covalent acetyl-enzyme intermediate. *Nat Commun* **6**, 7673-7685, doi:10.1038/ncomms8673 (2015).
- 131 Vlasak, R., Luytjes, W., Spaan, W. & Palese, P. Human and bovine coronaviruses recognize sialic acid-containing receptors similar to those of influenza C viruses. *Proc Natl Acad Sci U S A* **85**, 4526-4529, doi:10.1073/pnas.85.12.4526 (1988).
- 132 Huang, X. *et al.* Human coronavirus HKU1 spike protein uses O-acetylated sialic acid

- as an attachment receptor determinant and employs hemagglutinin-esterase protein as a receptor-destroying enzyme. *J Virol* **89**, 7202-7213, doi:10.1128/JVI.00854-15 (2015).
- 133 Zeng, Q., Langereis, M., Vliet, A., Huizinga, E. & de Groot, R. Structure of coronavirus hemagglutinin-esterase offers insight into Corona- and Influenza virus evolution. *Proc Natl Acad Sci U S A* **105**, 9065-9069, doi:10.1073/pnas.0800502105 (2008).
- 134 Bakkers, M. J. *et al.* Betacoronavirus adaptation to humans involved progressive loss of hemagglutinin-esterase lectin activity. *Cell Host Microbe* **21**, 356-366, doi:10.1016/j.chom.2017.02.008 (2017).
- 135 Hulswit, R. J. G. *et al.* Human coronaviruses OC43 and HKU1 bind to 9-O-acetylated sialic acids via a conserved receptor-binding site in spike protein domain A. *Proc Natl Acad Sci U S A* **116**, 2681-2690, doi:10.1073/pnas.1809667116 (2019).
- 136 Tortorici, M. A. *et al.* Structural basis for human coronavirus attachment to sialic acid receptors. *Nat Struct Mol Biol* **26**, 481-489, doi:10.1038/s41594-019-0233-y (2019).
- 137 Lambeir, A. M., Durinx, C., Scharpe, S. & De Meester, I. Dipeptidyl-peptidase IV from bench to bedside: an update on structural properties, functions, and clinical aspects of the enzyme DPP IV. *Crit Rev Clin Lab Sci* **40**, 209-294, doi:10.1080/713609354 (2003).
- 138 Raj, V. S. *et al.* Dipeptidyl peptidase 4 is a functional receptor for the emerging human coronavirus-EMC. *Nature* **495**, 251-254, doi:10.1038/nature12005 (2013).
- 139 Letko, M. *et al.* Adaptive evolution of MERS-CoV to species variation in DPP4. *Cell Rep* **24**, 1730-1737, doi:10.1016/j.celrep.2018.07.045 (2018).

- 140 Lu, G. *et al.* Molecular basis of binding between novel human coronavirus MERS-CoV and its receptor CD26. *Nature* **500**, 227-231, doi:10.1038/nature12328 (2013).
- 141 Wang, N. *et al.* Structure of MERS-CoV spike receptor-binding domain complexed with human receptor DPP4. *Cell Res* **23**, 986-993, doi:10.1038/cr.2013.92 (2013).
- 142 Yuan, Y. *et al.* Cryo-EM structures of MERS-CoV and SARS-CoV spike glycoproteins reveal the dynamic receptor binding domains. *Nat Commun* **8**, 15092-15101, doi:10.1038/ncomms15092 (2017).
- 143 Qing, E., Hantak, M. P., Galpalli, G. G. & Gallagher, T. Evaluating MERS-CoV entry pathways. *Methods Mol Biol* **2099**, 9-20, doi:10.1007/978-1-0716-0211-9_2 (2020).
- 144 Li, W. *et al.* Angiotensin-converting enzyme 2 is a functional receptor for the SARS coronavirus. *Nature* **426**, 450-454, doi:10.1038/nature02145 (2003).
- 145 Li, F., Li, W., Farzan, M. & Harrison, S. Structure of SARS coronavirus spike receptor-binding domain complexed with receptor. *Science* **309**, 1864-1868, doi:10.1126/science.1116480 (2005).
- 146 Wong, S. K., Li, W., Moore, M. J., Choe, H. & Farzan, M. A 193-amino acid fragment of the SARS coronavirus S protein efficiently binds angiotensin-converting enzyme 2. *J Biol Chem* **279**, 3197-3201, doi:10.1074/jbc.C300520200 (2004).
- 147 Du, L. *et al.* The spike protein of SARS-CoV--a target for vaccine and therapeutic development. *Nat Rev Microbiol* **7**, 226-236, doi:10.1038/nrmicro2090 (2009).
- 148 Qu, X. X. *et al.* Identification of two critical amino acid residues of the severe acute respiratory syndrome coronavirus spike protein for its variation in zoonotic tropism transition via a double substitution strategy. *J Biol Chem* **280**, 29588-29595,

- doi:10.1074/jbc.M500662200 (2005).
- 149 Hofmann, H. & Pohlmann, S. Cellular entry of the SARS coronavirus. *Trends Microbiol* **12**, 466-472, doi:10.1016/j.tim.2004.08.008 (2004).
- 150 Matsuyama, S. *et al.* Efficient activation of the severe acute respiratory syndrome coronavirus spike protein by the transmembrane protease TMPRSS2. *J Virol* **84**, 12658-12664, doi:10.1128/JVI.01542-10 (2010).
- 151 Huang, I. C. *et al.* SARS coronavirus, but not human coronavirus NL63, utilizes cathepsin L to infect ACE2-expressing cells. *J Biol Chem* **281**, 3198-3203, doi:10.1074/jbc.M508381200 (2006).
- 152 Wang, H. *et al.* SARS coronavirus entry into host cells through a novel clathrin- and caveolae-independent endocytic pathway. *Cell Res* **18**, 290-301, doi:10.1038/cr.2008.15 (2008).
- 153 Lu, R. *et al.* Genomic characterisation and epidemiology of 2019 novel coronavirus: implications for virus origins and receptor binding. *The Lancet* **395**, 565-574, doi:10.1016/s0140-6736(20)30251-8 (2020).
- 154 Hoffmann, M. *et al.* SARS-CoV-2 cell entry depends on ACE2 and TMPRSS2 and is blocked by a clinically proven protease inhibitor. *Cell*, doi:10.1016/j.cell.2020.02.052 (2020).
- 155 Ziegler, C. G. K. *et al.* SARS-CoV-2 receptor ACE2 is an interferon-stimulated gene in human airway epithelial cells and is detected in specific cell subsets across tissues. *Cell*, doi:10.1016/j.cell.2020.04.035 (2020).
- 156 Lamers, M. M. *et al.* SARS-CoV-2 productively infects human gut enterocytes.

- Science*, eabc1669, doi:10.1126/science.abc1669 (2020).
- 157 Lan, J. *et al.* Structure of the SARS-CoV-2 spike receptor-binding domain bound to the ACE2 receptor. *Nature*, doi:10.1038/s41586-020-2180-5 (2020).
- 158 Walls, A. C. *et al.* Structure, Function, and Antigenicity of the SARS-CoV-2 Spike Glycoprotein. *Cell* **181**, 281-292.e286, doi:10.1016/j.cell.2020.02.058 (2020).
- 159 Wan, Y., Shang, J., Graham, R., Baric, R. S. & Li, F. Receptor recognition by the novel coronavirus from Wuhan: an analysis based on decade-long structural studies of SARS coronavirus. *J Virol* **94**, doi:10.1128/JVI.00127-20 (2020).
- 160 Yan, R. *et al.* Structural basis for the recognition of the SARS-CoV-2 by full-length human ACE2. *Science*, eabb2762, doi:10.1126/science.abb2762 (2020).
- 161 Shang, J. *et al.* Structural basis of receptor recognition by SARS-CoV-2. *Nature*, doi:10.1038/s41586-020-2179-y (2020).
- 162 Wrapp, D. *et al.* Cryo-EM structure of the 2019-nCoV spike in the prefusion conformation. *Science* **367**, 1260-1263, doi:10.1126/science.abb2507 (2020).
- 163 Wang, Q. *et al.* Structural and functional basis of SARS-CoV-2 entry by using human ACE2. *Cell*, doi:10.1016/j.cell.2020.03.045 (2020).
- 164 Wang, K. *et al.* SARS-CoV-2 invades host cells via a novel route CD147-spike protein *bioRxiv*, doi:10.1101/2020.03.14.988345 (2020).
- 165 Shang, J. *et al.* Cell entry mechanisms of SARS-CoV-2. *Proc Natl Acad Sci U S A*, 202003138, doi:10.1073/pnas.2003138117 (2020).
- 166 Sungnak, W. *et al.* SARS-CoV-2 entry factors are highly expressed in nasal epithelial cells together with innate immune genes. *Nat Med*, doi:10.1038/s41591-020-0868-6

- (2020).
- 167 Ou, X. *et al.* Characterization of spike glycoprotein of SARS-CoV-2 on virus entry and its immune cross-reactivity with SARS-CoV. *Nat Commun* **11**, 1620-1632, doi:10.1038/s41467-020-15562-9 (2020).
- 168 Liu, C. *et al.* Research and development on therapeutic agents and vaccines for COVID-19 and related human coronavirus diseases. *ACS Central Science*, doi:10.1021/acscentsci.0c00272 (2020).
- 169 Clercq, E. D. Antiviral activity spectrum and target of action of different classes of nucleoside analogues. *Nucleosides and Nucleotides* **13**, 1271-1295, doi:10.1080/15257779408012151 (1994).
- 170 De Clercq, E. & Li, G. Approved antiviral drugs over the past 50 years. *Clin Microbiol Rev* **29**, 695-747, doi:10.1128/CMR.00102-15 (2016).
- 171 Graci, J. D. & Cameron, C. E. Mechanisms of action of ribavirin against distinct viruses. *Rev Med Virol* **16**, 37-48, doi:10.1002/rmv.483 (2006).
- 172 Menachery, V. D. *et al.* SARS-like cluster of circulating bat coronaviruses shows potential for human emergence. *Nat Med* **21**, 1508-1513, doi:10.1038/nm.3985 (2015).
- 173 Sheahan, T. P. *et al.* Broad-spectrum antiviral GS-5734 inhibits both epidemic and zoonotic coronaviruses. *Sci Transl Med* **9**, eaal3653, doi:10.1126/scitranslmed.aal3653 (2017).
- 174 Sheahan, T. P. *et al.* Comparative therapeutic efficacy of remdesivir and combination lopinavir, ritonavir, and interferon beta against MERS-CoV. *Nat Commun* **11**, 222-236,

- doi:10.1038/s41467-019-13940-6 (2020).
- 175 Holshue, M. L. *et al.* First case of 2019 novel coronavirus in the United States. *N Engl J Med* **382**, 929-936, doi:10.1056/NEJMoa2001191 (2020).
- 176 Wang, M. *et al.* Remdesivir and chloroquine effectively inhibit the recently emerged novel coronavirus (2019-nCoV) in vitro. *Cell Res* **30**, 269-271, doi:10.1038/s41422-020-0282-0 (2020).
- 177 Li, G. & De Clercq, E. Therapeutic options for the 2019 novel coronavirus (2019-nCoV). *Nat Rev Drug Discov* **19**, 149-150, doi:10.1038/d41573-020-00016-0 (2020).
- 178 Grein, J. *et al.* Compassionate Use of Remdesivir for Patients with Severe Covid-19. *N Engl J Med*, doi:10.1056/NEJMoa2007016 (2020).
- 179 Yin, W. *et al.* Structural basis for inhibition of the RNA-dependent RNA polymerase from SARS-CoV-2 by remdesivir. *Science*, eabc1560, doi:10.1126/science.abc1560 (2020).
- 180 Walmsley, S. *et al.* Lopinavir–ritonavir versus nelfinavir for the initial treatment of HIV infection. *N Engl J Med* **346**, 2039-2046, doi:10.1056/NEJMoa012354 (2002).
- 181 Chu, C. M. *et al.* Role of lopinavir/ritonavir in the treatment of SARS: initial virological and clinical findings. *Thorax* **59**, 252-256, doi:10.1136/thorax.2003.012658 (2004).
- 182 Chan, J. F. *et al.* Treatment with lopinavir/ritonavir or interferon-beta1b improves outcome of MERS-CoV infection in a nonhuman primate model of common marmoset. *J Infect Dis* **212**, 1904-1913, doi:10.1093/infdis/jiv392 (2015).
- 183 Cao, B. *et al.* A trial of lopinavir-ritonavir in adults hospitalized with severe COVID-19.

- N Engl J Med*, doi:10.1056/NEJMoa2001282 (2020).
- 184 Sheahan, T. P. *et al.* An orally bioavailable broad-spectrum antiviral inhibits SARS-CoV-2 in human airway epithelial cell cultures and multiple coronaviruses in mice. *Sci Transl Med*, eabb5883, doi:10.1126/scitranslmed.abb5883 (2020).
- 185 Gao, Y. *et al.* Structure of the RNA-dependent RNA polymerase from COVID-19 virus. *Science*, eabb7498, doi:10.1126/science.abb7498 (2020).
- 186 Jin, Z. *et al.* Structure of Mpro from COVID-19 virus and discovery of its inhibitors. *Nature*, doi:10.1038/s41586-020-2223-y (2020).
- 187 Zhang, L. *et al.* Crystal structure of SARS-CoV-2 main protease provides a basis for design of improved α -ketoamide inhibitors. *Science*, eabb3405, doi:10.1126/science.abb3405 (2020).
- 188 Dai, W. *et al.* Structure-based design of antiviral drug candidates targeting the SARS-CoV-2 main protease. *Science*, eabb4489, doi:10.1126/science.abb4489 (2020).
- 189 Menachery, V. D. *et al.* Pathogenic influenza viruses and coronaviruses utilize similar and contrasting approaches to control interferon-stimulated gene responses. *mBio* **5**, e01174, doi:10.1128/mBio.01174-14 (2014).
- 190 Zhao, Z. *et al.* Description and clinical treatment of an early outbreak of severe acute respiratory syndrome (SARS) in Guangzhou, PR China. *J Med Microbiol* **52**, 715-720, doi:10.1099/jmm.0.05320-0 (2003).
- 191 Omrani, A. S. *et al.* Ribavirin and interferon alfa-2a for severe Middle East respiratory syndrome coronavirus infection: a retrospective cohort study. *Lancet Infect Dis* **14**,

- 1090-1095, doi:10.1016/s1473-3099(14)70920-x (2014).
- 192 Falzarano, D. *et al.* Treatment with interferon-alpha2b and ribavirin improves outcome in MERS-CoV-infected rhesus macaques. *Nat Med* **19**, 1313-1317, doi:10.1038/nm.3362 (2013).
- 193 Blanco-Melo, D. *et al.* Imbalanced host response to SARS-CoV-2 drives development of COVID-19. *Cell*, doi:10.1016/j.cell.2020.04.026 (2020).
- 194 Loutfy, M. R. *et al.* Interferon alfacon-1 plus corticosteroids in severe acute respiratory syndrome: a preliminary study. *JAMA* **290**, 3222-3228, doi:10.1001/jama.290.24.3222 (2003).
- 195 Wang, H. *et al.* Fatal aspergillosis in a patient with SARS who was treated with corticosteroids. *N Engl J Med* **349**, 507-508, doi:10.1056/NEJM200307313490519 (2003).
- 196 Russell, C. D., Millar, J. E. & Baillie, J. K. Clinical evidence does not support corticosteroid treatment for 2019-nCoV lung injury. *The Lancet* **395**, 473-475, doi:10.1016/s0140-6736(20)30317-2 (2020).
- 197 Totura, A. L. & Bavari, S. Broad-spectrum coronavirus antiviral drug discovery. *Expert Opin Drug Discov* **14**, 397-412, doi:10.1080/17460441.2019.1581171 (2019).
- 198 Soo, Y. *et al.* Retrospective comparison of convalescent plasma with continuing high-dose methylprednisolone treatment in SARS patients. *Clin Microbiol Infect* **10**, 676-678, doi:10.1111/j.1469-0691.2004.00956.x (2004).
- 199 Arabi, Y. M. *et al.* Feasibility of using convalescent plasma immunotherapy for MERS-CoV infection, Saudi Arabia. *Emerg Infect Dis* **22**, 1554-1561,

- doi:10.3201/eid2209.151164 (2016).
- 200 Zhu, Z. *et al.* Potent cross-reactive neutralization of SARS coronavirus isolates by human monoclonal antibodies. *Proc Natl Acad Sci U S A* **104**, 12123-12128, doi:10.1073/pnas.0701000104 (2007).
- 201 Jiang, L. *et al.* Potent neutralization of MERS-CoV by human neutralizing monoclonal antibodies to the viral spike glycoprotein. *Sci Transl Med* **6**, 234ra259, doi:10.1126/scitranslmed.3008140 (2014).
- 202 Pascal, K. E. *et al.* Pre- and postexposure efficacy of fully human antibodies against Spike protein in a novel humanized mouse model of MERS-CoV infection. *Proc Natl Acad Sci U S A* **112**, 8738-8743, doi:10.1073/pnas.1510830112 (2015).
- 203 de Wit, E., van Doremalen, N., Falzarano, D. & Munster, V. J. SARS and MERS: recent insights into emerging coronaviruses. *Nat Rev Microbiol* **14**, 523-534, doi:10.1038/nrmicro.2016.81 (2016).
- 204 Shanmugaraj, B., Siri wattananon, K., Wangkanont, K. & Phoolcharoen, W. Perspectives on monoclonal antibody therapy as potential therapeutic intervention for Coronavirus disease-19 (COVID-19). *Asian Pac J Allergy Immunol*, doi:10.12932/AP-200220-0773 (2020).
- 205 Tian, X. *et al.* Potent binding of 2019 novel coronavirus spike protein by a SARS coronavirus-specific human monoclonal antibody. *Emerg Microbes Infect* **9**, 382-385, doi:10.1080/22221751.2020.1729069 (2020).
- 206 Ju, B. *et al.* Human neutralizing antibodies elicited by SARS-CoV-2 infection. *Nature*, doi:10.1038/s41586-020-2380-z (2020).

- 207 Shi, R. *et al.* A human neutralizing antibody targets the receptor binding site of SARS-CoV-2. *Nature*, doi:10.1038/s41586-020-2381-y (2020).
- 208 Wang, C. *et al.* A human monoclonal antibody blocking SARS-CoV-2 infection. *Nat Commun* **11**, 2251, doi:10.1038/s41467-020-16256-y (2020).
- 209 Wrapp, D. *et al.* Structural Basis for Potent Neutralization of Betacoronaviruses. *Cell*, doi:10.1016/j.cell.2020.04.031 (2020).
- 210 Chen, L., Xiong, J., Bao, L. & Shi, Y. Convalescent plasma as a potential therapy for COVID-19. *Lancet Infect Dis*, doi:10.1016/s1473-3099(20)30141-9 (2020).
- 211 Monteil, V. *et al.* Inhibition of SARS-CoV-2 infections in engineered human tissues using clinical-grade soluble human ACE2. *Cell*, doi:10.1016/j.cell.2020.04.004 (2020).
- 212 Piot, P. *et al.* Immunization: vital progress, unfinished agenda. *Nature* **575**, 119-129, doi:10.1038/s41586-019-1656-7 (2019).
- 213 Lu, S. Timely development of vaccines against SARS-CoV-2. *Emerg Microbes Infect* **9**, 542-544, doi:10.1080/22221751.2020.1737580 (2020).
- 214 Zhang, N., Tang, J., Lu, L., Jiang, S. & Du, L. Receptor-binding domain-based subunit vaccines against MERS-CoV. *Virus Res* **202**, 151-159, doi:10.1016/j.virusres.2014.11.013 (2015).
- 215 Graham, R. L., Donaldson, E. F. & Baric, R. S. A decade after SARS: strategies for controlling emerging coronaviruses. *Nat Rev Microbiol* **11**, 836-848, doi:10.1038/nrmicro3143 (2013).
- 216 Wang, L. *et al.* Evaluation of candidate vaccine approaches for MERS-CoV. *Nat Commun* **6**, 7712-7723, doi:10.1038/ncomms8712 (2015).

- 217 Bao, L. *et al.* The pathogenicity of SARS-CoV-2 in hACE2 transgenic mice. *Nature*, doi:10.1038/s41586-020-2312-y (2020).
- 218 Shan, C. *et al.* Infection with novel coronavirus (SARS-CoV-2) causes pneumonia in Rhesus macaques. *Cell Res*, doi:10.1038/s41422-020-0364-z (2020).
- 219 Deng, W. *et al.* Rhesus macaques can be effectively infected with SARS-CoV-2 via ocular conjunctival route. *bioRxiv*, doi:10.1101/2020.03.13.990036 (2020).
- 220 Rockx, B. *et al.* Comparative pathogenesis of COVID-19, MERS, and SARS in a nonhuman primate model. *Science*, eabb7314, doi:10.1126/science.abb7314 (2020).
- 221 Gao, Q. *et al.* Rapid development of an inactivated vaccine candidate for SARS-CoV-2. *Science*, eabc1932, doi:10.1126/science.abc1932 (2020).
- 222 Zhu, F.-C. *et al.* Safety, tolerability, and immunogenicity of a recombinant adenovirus type-5 vectored COVID-19 vaccine: a dose-escalation, open-label, non-randomised, first-in-human trial. *The Lancet*, doi:10.1016/s0140-6736(20)31208-3 (2020).
- 223 Zhang, K. *et al.* Clinically Applicable AI System for Accurate Diagnosis, Quantitative Measurements and Prognosis of COVID-19 Pneumonia Using Computed Tomography. *Cell*, doi:10.1016/j.cell.2020.04.045 (2020).
- 224 Ferguson, N. M. *et al.* Impact of non-pharmaceutical interventions (NPIs) to reduce COVID19 mortality and healthcare demand. *Imperial College COVID-19 Response Team*, doi:10.25561/77482 (2020).
- 225 Lebov, J. *et al.* A framework for One Health research. *One Health* **3**, 44-50, doi:10.1016/j.onehlt.2017.03.004 (2017).

Figure legends

Figure 1. The taxonomy of the order *Nidovirales*. HCoV, human coronavirus; MERS, Middle East respiratory syndrome; SARS, severe acute respiratory syndrome.

Figure 2. Timeline for the emergency of human coronaviruses. HCoV, human coronavirus; MERS, Middle East respiratory syndrome; SARS, severe acute respiratory syndrome.

Figure 3. Genomes and structures of human coronaviruses. (a) The ultrastructural morphology of coronavirus on the left illustration (the Centers for Disease Control and Prevention, CDC) and right virus particle. (b) The genomes of HCoVs contain a single-stranded, positive-sense RNA (ssRNA) genome of 27–32kb in size. The 5'-terminal ORF1a/b within two-thirds of the genome encodes two large polyproteins 1a (pp1a) and pp1b. These polyproteins are cleaved by PLpro and 3CLpro, also known as Mpro, to produce non-structural proteins (nsps), including RdRp and Hel, which are important enzymes involved in the transcription and replication. The 3' one-third of genome encodes four structural proteins: Spike (S), Membrane (M), Envelope (E) and Nucleocapsid (N), which are essential for virus-cell receptor binding and virion assembly, and other non-structural proteins along with a set of accessory proteins unique to each virus species. Some coronaviruses express an additional structural protein, hemagglutinin-esterase (HE). (c) The S protein of HCoVs consists of S1 subunit and S2 subunit. The S1 region contains an NTD and a CTD (also referred to as the RBD), whereas the S2 region includes a TM region, FP, HR1 and HR2. The HE glycoprotein consists of two functional domains: a corresponding sialate O-acetyltransferase domain and an O-acetylated sialic acid binding domain. HCoV-OC43 and HKU1 bind 9-O-Ac-Sia via NTD of S1 subunit and mediate sialate-O-acetyltransferase activity by RDE domain of HE protein. Other coronaviruses mediate attachment to the cellular receptors by RBD (CTD) in S1 region. Herein, we compare and contrast genome structures of seven identified HCoVs strains HCoV-229E, HCoV-NL63, HCoV-OC43, HCoV-HKU1, MERS-CoV, SARS-CoV and SARS-CoV-2.

Figure 4. The structural comparison of RBD bound with receptor and RBD subdomains in the three coronaviruses. (a) Overall structure of RBD bound with DPP4 (PDB ID: 4KR0), and (b) schematic illustration topology of the core structure and RBM in the MERS-CoV RBD. (c) Overall structure of RBD bound with ACE2 (PDB ID: 2AJF), and (d) schematic illustration topology of the core structure and RBM in the SARS-CoV RBD. (e) Overall structure of RBD bound with ACE2 (PDB ID: 6M0J), and (f) schematic illustration topology of the core structure and RBM in the SARS-CoV-2 RBD. β strands are drawn as arrows and α helices are drawn as cylinders. The disulfide bonds are drawn as yellow sticks. The core subdomain is colored in green and the receptor-binding subdomain is colored in red.

Table 1. Comparison of host, genome features, receptor-binding site, and receptor of human coronaviruses.

HCoV	Host		Genome features		Receptor-binding sites		Receptor
	Natural	Intermediate	Size(nt)	GC (%)	RBD	RBM	Protein Determinant
HCoV-229E	Bats	Camelids	27240	38	417-547	--	APN
HCoV-NL63	Bats	Unknown	27553	34	476-616	--	ACE2
HCoV-OC43	Rodents	Cattle	30738	37	15-302	--	Unknown 9-O-Ac-Sia
HCoV-HKU1	Rodents	Unknown	29926	32	15-302	--	Unknown 9-O-Ac-Sia
MERS-CoV	Bats	Camels	30119	41	367-606	484-567	DPP4
SARS-CoV	Bats	Civets	29727	41	306-527	424-494	ACE2
SARS-CoV-2	Bats	Pangolins ?	29903	38	333-527	438-506	ACE2

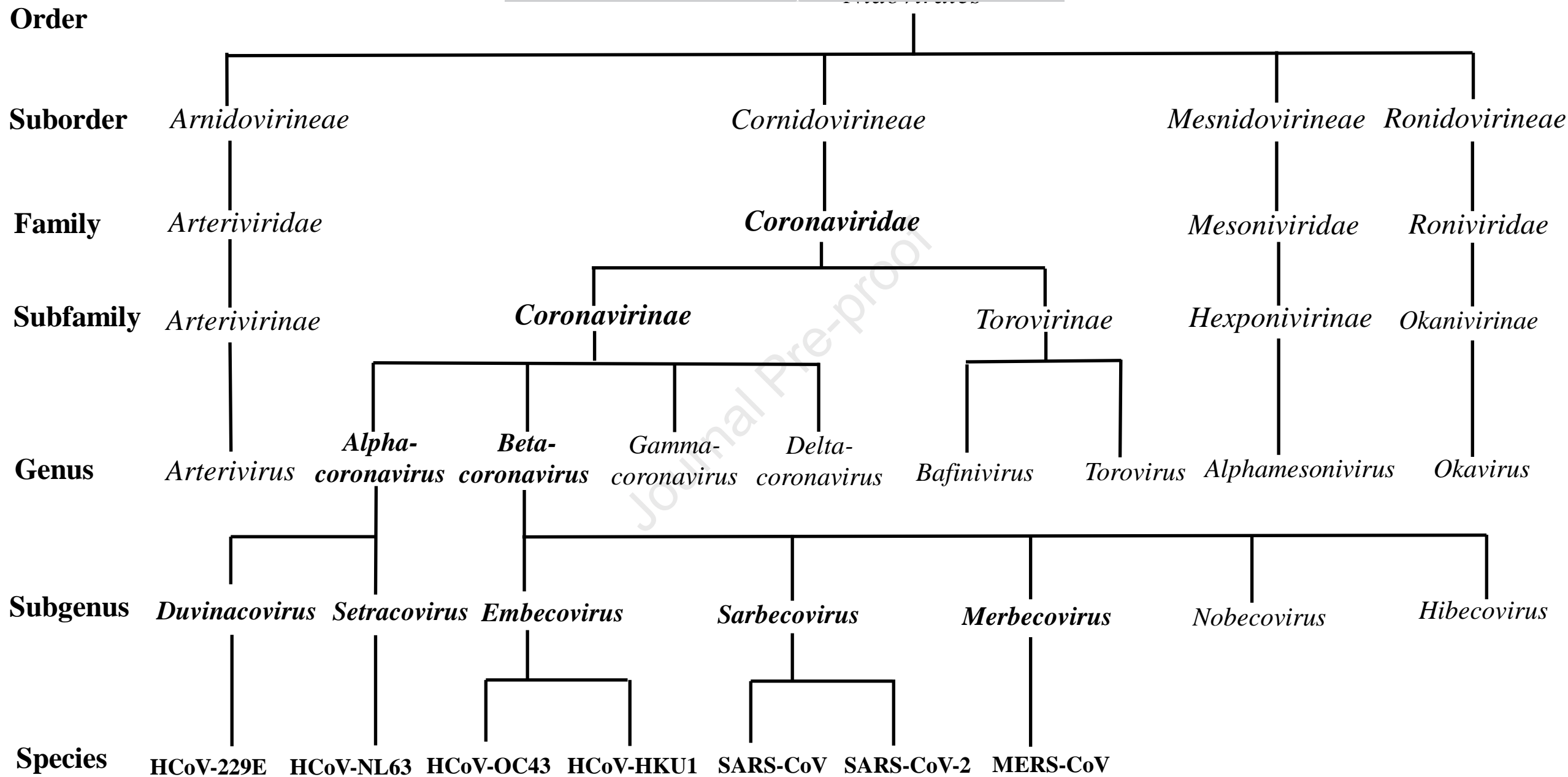

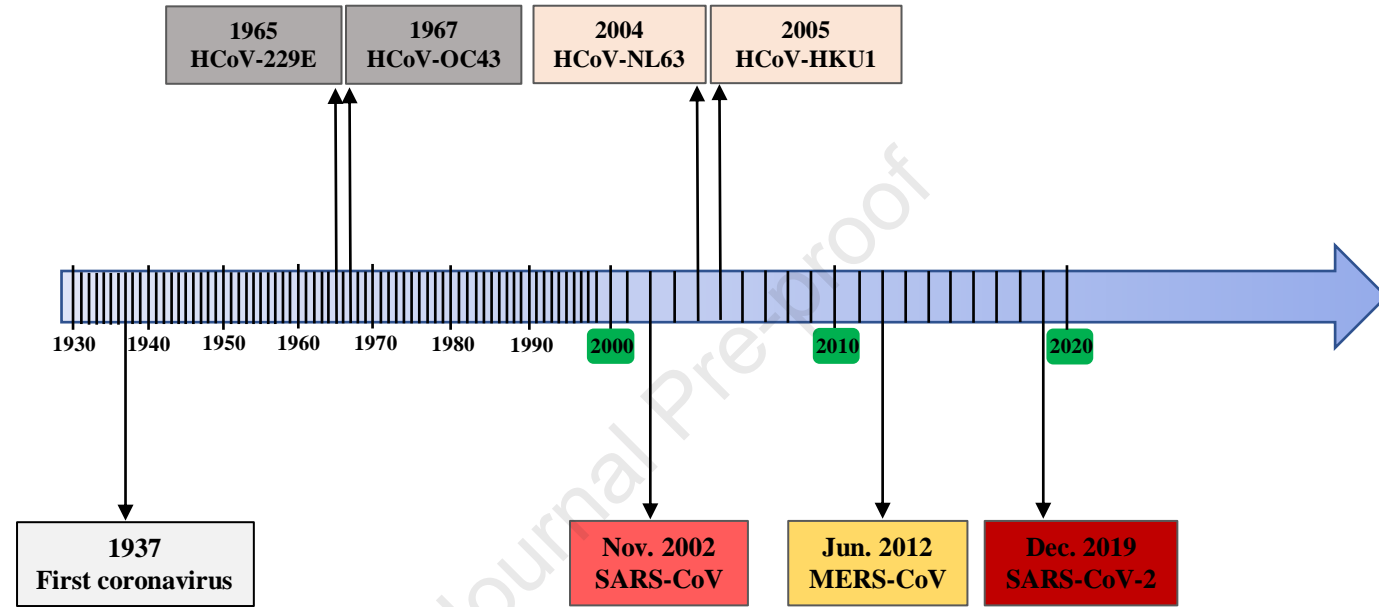

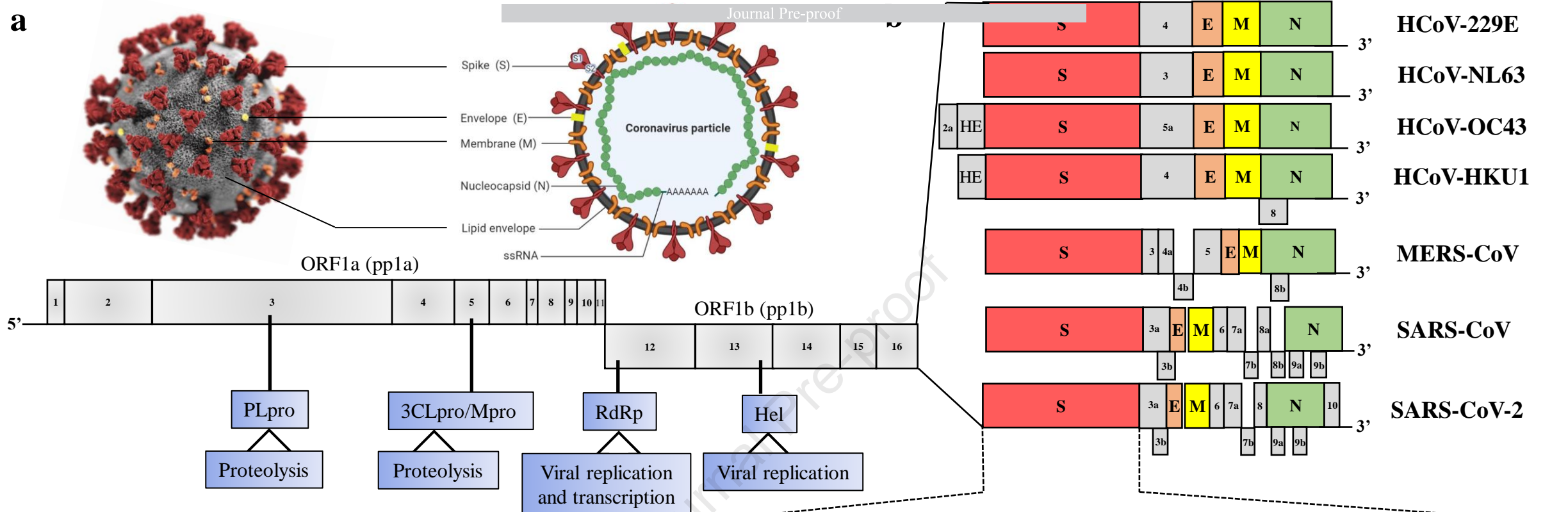
a

5'

ORF1a (pp1a)

ORF1b (pp1b)

PLpro

Proteolysis

3CLpro/Mpro

Proteolysis

RdRp

Viral replication
and transcription

Hel

Viral replication

c

S1 subunit

S2 subunit



ssRNA, single-stranded RNA
 ORF, open reading frame
 PLpro, papain-like cysteine protease
 3CLpro, 3C-like serine protease
 Mpro, main protease
 RdRp, RNA-dependent RNA
 Hel, helicase

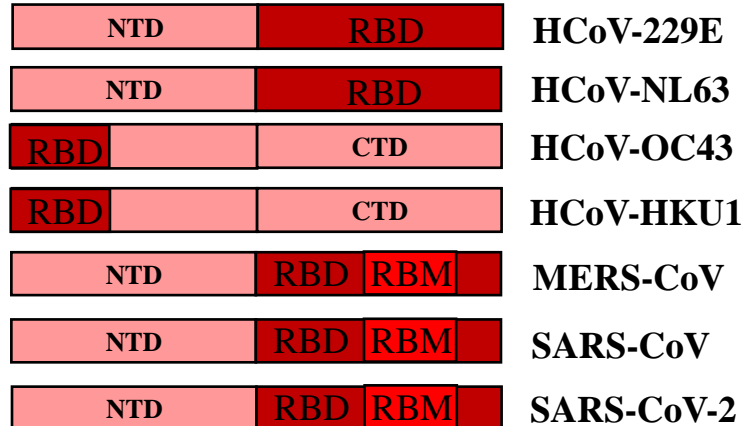

NTD, N-terminal domain
 CTD, C-terminal domain
 SP, signal peptide
 FP, fusion peptide
 HR1, heptad repeat 1
 HR2, heptad repeat 2
 TM, transmembrane domain
 CP, cytoplasmic peptide

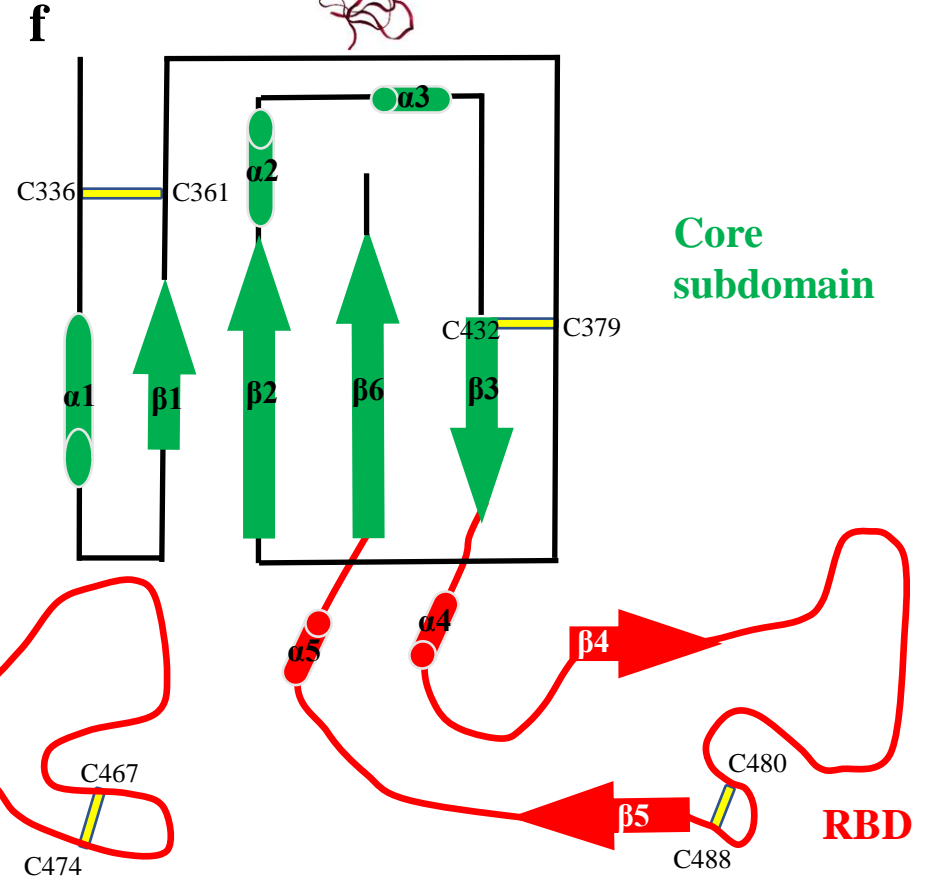
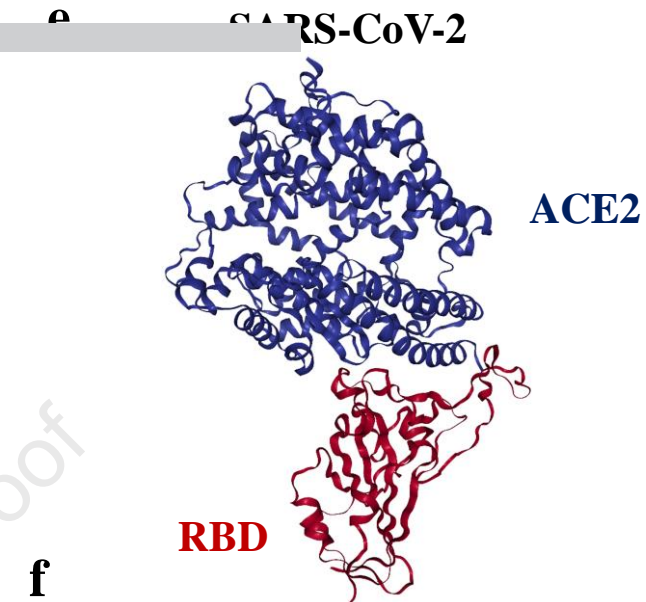
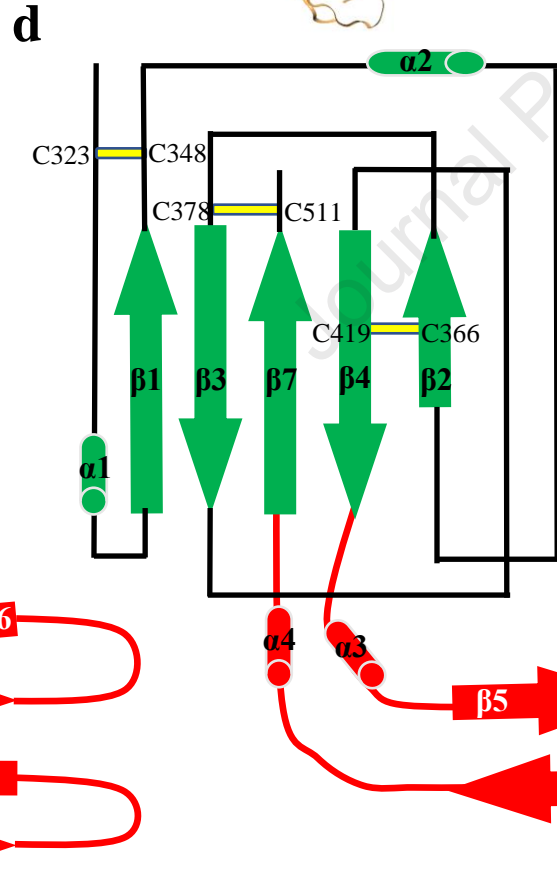
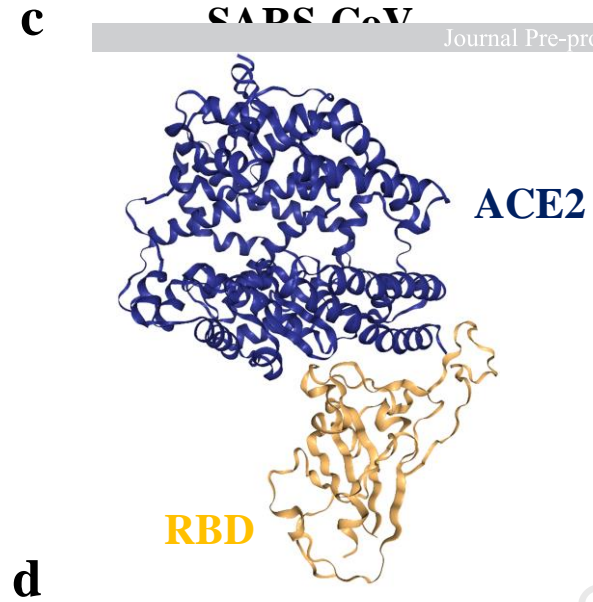
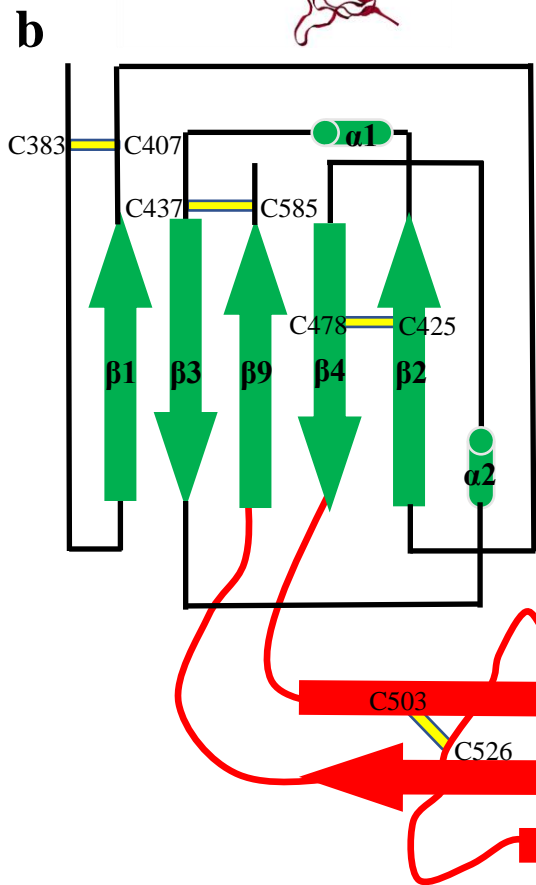
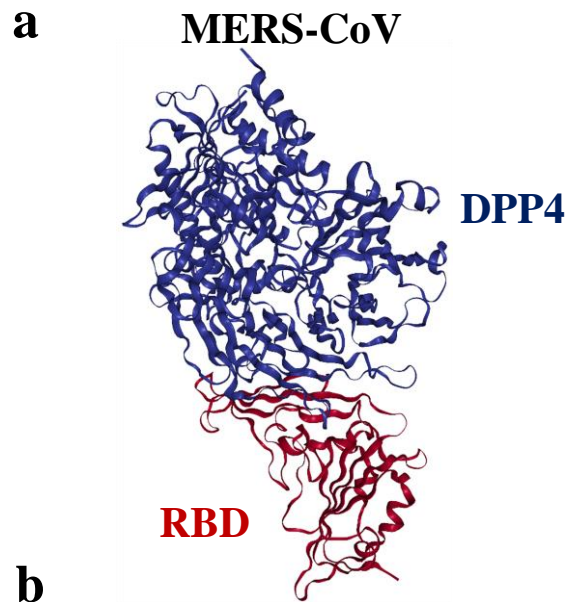



Medicine in Journal Pre-proof Novel Technology and Devices

Manuscript title

Corresponding author

Article type

Funding Source

All sources of funding should also be acknowledged and you should declare any involvement of study sponsors in the study design; collection, analysis and interpretation of data; the writing of the manuscript; the decision to submit the manuscript for publication. If the study sponsors had no such involvement, this should be stated.

Please state any sources of funding for your research:

Declarations

The journal requires that the corresponding author, signs on behalf of all authors, a declaration of conflicting interests. If you have nothing to declare in any of these categories then this should be stated.

A conflicting interest exists when professional judgment concerning a primary interest (such as patient's welfare or the validity of research) may be influenced by a secondary interest (such as financial gain or personal rivalry). It may arise for the authors when they have financial interest that may influence their interpretation of their results or those of others. Examples of potential conflicts of interest include employment, consultancies, stock ownership, honoraria, paid expert testimony, patent applications/registrations, and grants or other funding. If there are no interests to declare then please state this: 'The authors declare that there are no conflicts of interest.'

Please state any competing interests:

Ethical approval and informed consent (if applicable)

If the work involves the use of **human subjects**, the author should ensure that the work described has been carried out in accordance with [The Code of Ethics of the World Medical Association](#) (Declaration of Helsinki) for experiments involving humans. The manuscript should be in line with the [Recommendations for the Conduct, Reporting, Editing and Publication of Scholarly Work in Medical Journals](#) and aim for the inclusion of representative human populations (sex, age and ethnicity) as per those recommendations. The terms [sex and gender](#) should be used correctly.

All **animal experiments** should comply with the [ARRIVE guidelines](#) and should be carried out in accordance with the U.K. Animals (Scientific Procedures) Act, 1986 and associated guidelines, [EU Directive 2010/63/EU for animal experiments](#), or the National Institutes of Health guide for the care and use of Laboratory animals (NIH Publications No. 8023, revised 1978). The sex of animals must be indicated, and where appropriate, the influence (or association) of sex on the results of the study.

The author should also clearly indicate in the Material and methods section of the manuscript that applicable guidelines, regulations and laws have been followed and required ethical approval has been obtained.

Patient consent (if applicable)

Completion of this section is mandatory for Case Reports, Clinical Pictures, and Adverse Drug Reactions. Please sign below to confirm that all necessary consents required by applicable law from any relevant patient, research participant, and/or other individual whose information is included in the article have been obtained in writing. The signed consent form(s) should be retained by the corresponding author and NOT sent to Medicine in Novel Technology and Devices.

Author Contribution to Study

All authors listed on your paper must have made significant contributions to the study. To ensure clarity, you are required to enter the specific details of each author's contribution, which must substantiate the inclusion of each person on the manuscript. Roles for all authors should be described using the relevant CRediT roles: Conceptualization; Data curation; Formal analysis; Funding acquisition; Investigation; Methodology; Project administration; Resources; Software; Supervision; Validation; Visualization; Roles/Writing - original draft; Writing - review & editing.

Example:

Elizabeth Ash: Conceptualization, Methodology, Software. Catriona Fennell: Data curation, Writing- Original draft preparation. Linda Gruner: Visualization, Investigation. Ton Bos: Supervision. Ramya Kannan: Software, Validation. Kalaivani Moorthy: Writing- Reviewing and Editing, Supervision. Lucia Muñoz Franco: Data curation, Software, Validation.

Please detail this information below (submit additional sheets as necessary):

Corresponding author declaration

I [Signature] , the corresponding author of this manuscript, certify that the contributors' and conflicts of interest statements included in this paper are correct and have been approved by all co-authors.

Signature: